

DESCRIPTION

The multiple pumps are available in STANDARD and T.C. (short-tandem) versions.

The versatility of our pumps permits the assembling of a multiple pump using a single pump and making only a simple operation of disassembly/assembly.

- All our standard pumps are already present to engage another pump.
- A very limited quantity of kit "flange connections and accessories" gives a small stock value and mainly a rapid assistance to final users.

- The total of the torque absorbed by each pump shall be not in excess of the max. allowed torque on main shaft (see below scheme)

The max. torque absorbed by the follow pumps shall be not in excess of the torque transmitted by the rear draft gear.

- The power absorbed by the multiple pump is determined from total powers that each pump absorbed and it is calculated as follow:

$$P = \frac{c \times n \times p}{603000}$$

in which:

P = Max. absorbed power (Kw)

c = Pump displacement (cm³/rev)

n = Max. working speed (rpm)

p = Max. working pressure (bar)

TECHNICAL FEATURES

- Performance of units composing multiple pumps are the same as these of the corresponding single pumps.
- Max. rotation speed of multiple pumps is given by slower pump.
- Max. torque absorbed by each simple unit to grant a working limit at max. working pressure is calculated in the following way:

$$M = \frac{c \times p}{64}$$

in which:

M = Max absorbed input torque (ft·lbs)

c = Pump displacement (cm³/rev)

p = Max. working pressure (bar)

	Torque transmitted by the draft pump [Nm] (ft·lbs)								Torque transmitted by rear draft [Nm] (ft·lbs)
	Type 10	Type 11	Type 12	Type 13	Type 14	Type 15	Type 16	Type 17/27	
GR 1	18 (13.3)	18 (13.3)		30 (22.1)	30 (22.1)	30 (22.1)		12 (8.9)	18 (13.3)
GR 2	98 (72.3)	98 (72.3)	98 (72.3)	98 (72.3)	98 (72.3)	98 (72.3)	98 (72.3)	70 (51.6)	75 (55.3)
GR 3	240 (177)			240 (177)	240 (177)				240 (177)
GR 4	750 (553)								750 (553)

ORDERING CODE – TANDEMS

Tandem STANDARD

Are possible different combinations of all the group pumps (Gr.1 - Gr.2 - Gr.3 and Gr.4).
The suction of each pump is independent.

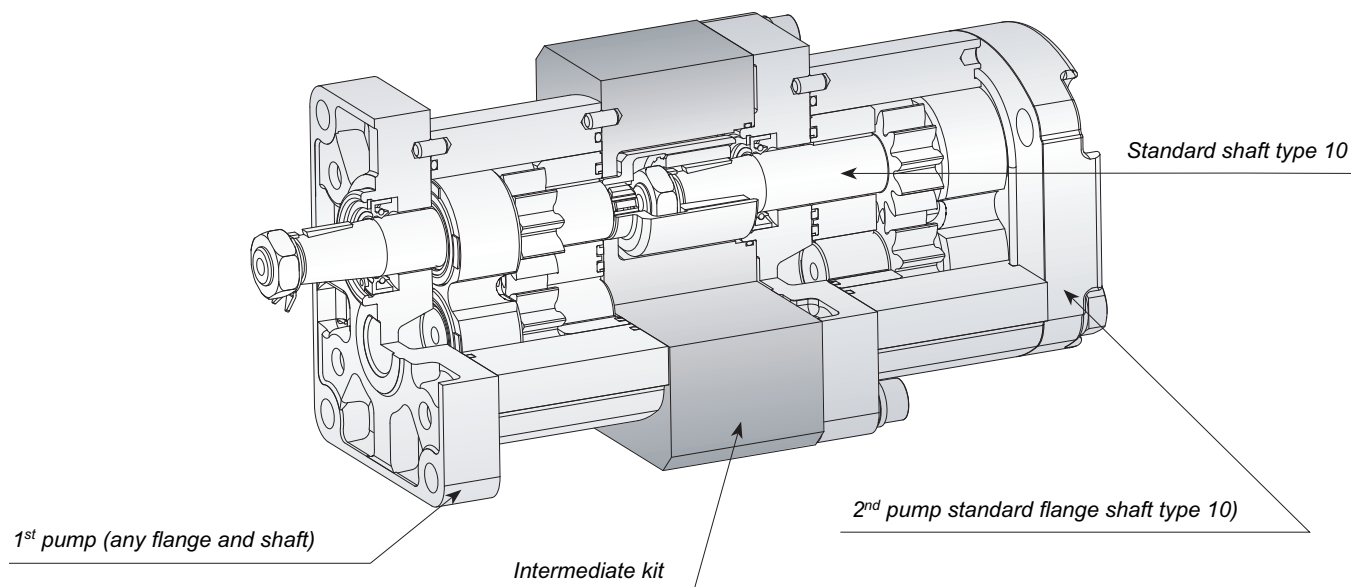

Example of ordering code

2SP A14 + 1SP A4.2 D SAE A - 10 G (VT)

2SP A14	First pump type	
1SP A4.2	Second pump type	
D	Clockwise rotation	D = Clockwise rotation S = Anticlockwise rotation
SAE A	Flange and version first pump flange	See corresponding single pump
10	Shaft type first pump	
G	Connections type	
(VT)	Optional	

Example of ordering code

3SP A36 + 2SP A14 + 1SP A3.2 D SAE B - 10 G (VT)

3SP A36	First pump type	
2SP A14	Second pump type	
1SP A3.2	Third pump type	
D	Clockwise rotation	D = Clockwise rotation S = Anticlockwise rotation
SAE B	Flange and version first pump flange	See corresponding single pump
10	Shaft type first pump	
G	Connections type	
(VT)	Optional	

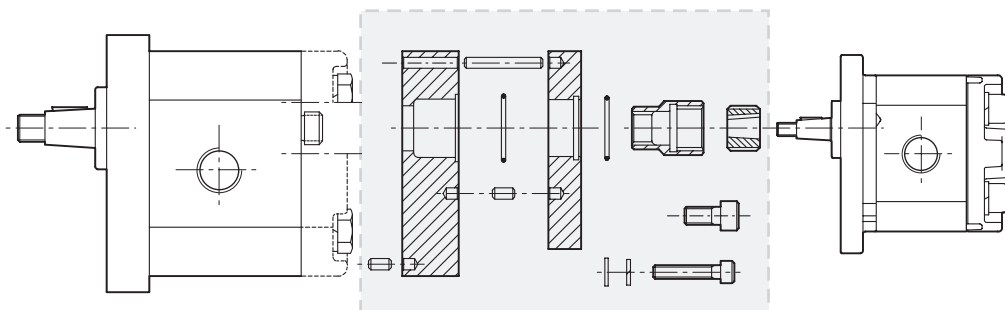

kit order code **01092110000000**

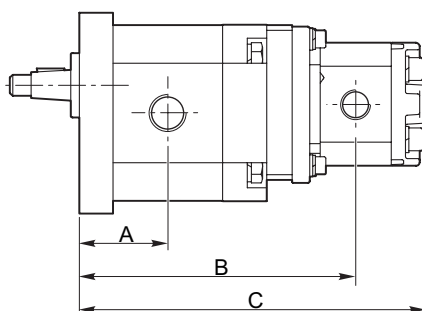

kit order code **01092110000000**

kit order code **01092110000000**

		mm (inch)			
		A	B	C	
2SP...26	+ 1SPA	9.8 (2.469)	62.7 (2.469)	198.1 (7.797)	254.2 (10.008)
		7.8 (2.469)	62.7 (2.469)	194.1 (7.642)	246.3 (9.697)
		6.3 (2.469)	62.7 (2.469)	191.3 (7.530)	240.6 (9.472)
		5 (2.469)	62.7 (2.469)	188.7 (7.429)	235.5 (9.272)
		4.2 (2.469)	62.7 (2.469)	187.2 (7.368)	232.4 (9.150)
		3.7 (2.469)	62.7 (2.469)	186.2 (7.331)	230.5 (9.075)
		3.2 (2.469)	62.7 (2.469)	185.2 (7.291)	228.5 (8.996)
		2.5 (2.469)	62.7 (2.469)	183.9 (7.238)	225.8 (8.890)
		2 (2.469)	62.7 (2.469)	182.9 (7.199)	223.8 (8.811)
		1.6 (2.469)	62.7 (2.469)	182.1 (7.169)	222.3 (8.752)
		1.2 (2.469)	62.7 (2.469)	181.3 (7.136)	220.6 (8.685)
		0.9 (2.469)	62.7 (2.469)	180.7 (7.114)	219.5 (8.642)

		mm (inch)			
		A	B	C	
2SP...22	+ 1SPA	9.8 (2.354)	59.8 (2.354)	192.3 (7.569)	248.4 (9.780)
		7.8 (2.354)	59.8 (2.354)	188.3 (7.413)	240.5 (9.469)
		6.3 (2.354)	59.8 (2.354)	185.5 (7.301)	234.8 (9.244)
		5 (2.354)	59.8 (2.354)	182.9 (7.201)	229.7 (9.043)
		4.2 (2.354)	59.8 (2.354)	181.4 (7.140)	226.6 (8.921)
		3.7 (2.354)	59.8 (2.354)	180.4 (7.102)	224.7 (8.846)
		3.2 (2.354)	59.8 (2.354)	179.4 (7.063)	222.7 (8.768)
		2.5 (2.354)	59.8 (2.354)	178.05 (7.010)	220.0 (8.661)
		2 (2.354)	59.8 (2.354)	177.1 (6.970)	218.0 (8.583)
		1.6 (2.354)	59.8 (2.354)	176.3 (6.941)	216.5 (8.524)
		1.2 (2.354)	59.8 (2.354)	175.5 (6.907)	214.8 (8.457)
		0.9 (2.354)	59.8 (2.354)	174.9 (6.886)	213.7 (8.413)

With B80C flange increase A, B, and C dimensions of 0.079 inch
 With E52C flange decrease A, B, and C dimensions of 0.106 inch

SEE PAGE 301 FOR PRICES

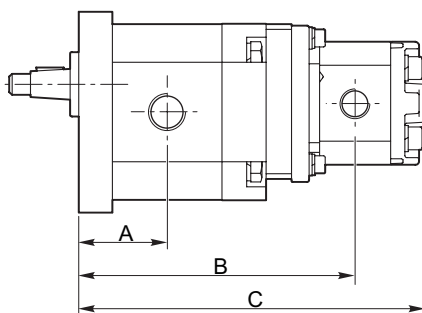

kit order code **010921100000000**

kit order code **010921100000000**

		mm (inch)			
		A	B	C	
2SP...19	+ 1SPA	9.8	57.3 (2.256)	187.3 (7.372)	243.4 (9.583)
		7.8	57.3 (2.256)	183.3 (7.217)	235.5 (9.272)
		6.3	57.3 (2.256)	180.5 (7.104)	229.8 (9.047)
		5	57.3 (2.256)	177.9 (7.004)	224.7 (8.846)
		4.2	57.3 (2.256)	176.4 (6.943)	221.6 (8.724)
		3.7	57.3 (2.256)	175.4 (6.906)	219.7 (8.650)
		3.2	57.3 (2.256)	174.4 (6.866)	217.7 (8.571)
		2.5	57.3 (2.256)	173.1 (6.813)	215.0 (8.465)
		2	57.3 (2.256)	172.1 (6.774)	213.0 (8.386)
		1.6	57.3 (2.256)	171.3 (6.744)	211.5 (8.327)
		1.2	57.3 (2.256)	170.5 (6.711)	209.8 (8.260)
		0.9	57.3 (2.256)	169.9 (6.689)	208.7 (8.217)
2SP...16	+ 1SPA	9.8	54.8 (2.157)	182.3 (7.175)	238.4 (9.386)
		7.8	54.8 (2.157)	178.3 (7.020)	230.5 (9.075)
		6.3	54.8 (2.157)	175.5 (6.907)	224.8 (8.850)
		5	54.8 (2.157)	172.9 (6.807)	219.7 (8.650)
		4.2	54.8 (2.157)	171.4 (6.746)	216.6 (8.528)
		3.7	54.8 (2.157)	170.4 (6.709)	214.7 (8.453)
		3.2	54.8 (2.157)	169.4 (6.669)	212.7 (8.374)
		2.5	54.8 (2.157)	168.1 (6.616)	210.0 (8.268)
		2	54.8 (2.157)	167.1 (6.577)	208.0 (8.189)
		1.6	54.8 (2.157)	166.3 (6.547)	206.5 (8.130)
		1.2	54.8 (2.157)	165.5 (6.514)	204.8 (8.063)
		0.9	54.8 (2.157)	164.9 (6.492)	203.7 (8.020)

		mm (inch)			
		A	B	C	
2SP...14	+ 1SPA	9.8	52.7 (2.075)	178.1 (7.010)	234.2 (9.220)
		7.8	52.7 (2.075)	174.1 (6.854)	226.3 (8.909)
		6.3	52.7 (2.075)	171.3 (6.742)	220.6 (8.685)
		5	52.7 (2.075)	168.7 (6.642)	215.5 (8.484)
		4.2	52.7 (2.075)	167.2 (6.581)	212.4 (8.362)
		3.7	52.7 (2.075)	166.2 (6.543)	210.5 (8.287)
		3.2	52.7 (2.075)	165.2 (6.504)	208.5 (8.209)
		2.5	52.7 (2.075)	163.9 (6.451)	205.8 (8.102)
		2	52.7 (2.075)	162.9 (6.411)	203.8 (8.024)
		1.6	52.7 (2.075)	162.1 (6.382)	202.3 (7.965)
		1.2	52.7 (2.075)	161.3 (6.348)	200.6 (7.898)
		0.9	52.7 (2.075)	160.7 (6.327)	199.5 (7.854)
2SP...11	+ 1SPA	9.8	50.2 (1.976)	173.1 (6.813)	229.2 (9.024)
		7.8	50.2 (1.976)	169.1 (6.657)	221.3 (8.713)
		6.3	50.2 (1.976)	166.3 (6.545)	215.6 (8.488)
		5	50.2 (1.976)	163.7 (6.445)	210.5 (8.287)
		4.2	50.2 (1.976)	162.2 (6.384)	207.4 (8.165)
		3.7	50.2 (1.976)	161.2 (6.346)	205.5 (8.091)
		3.2	50.2 (1.976)	160.2 (6.307)	203.5 (8.012)
		2.5	50.2 (1.976)	158.9 (6.254)	200.8 (7.906)
		2	50.2 (1.976)	157.9 (6.215)	198.8 (7.827)
		1.6	50.2 (1.976)	157.1 (6.185)	197.3 (7.768)
		1.2	50.2 (1.976)	156.3 (6.152)	195.6 (7.701)
		0.9	50.2 (1.976)	155.7 (6.130)	194.5 (7.657)

SEE PAGE 301 FOR PRICES

GROUP 2 + GROUP 1

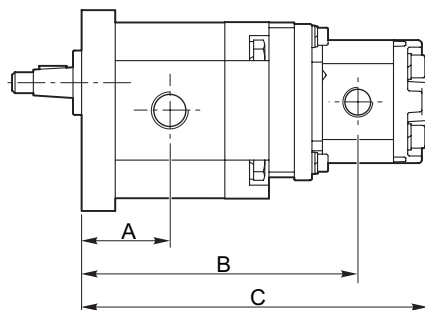

kit order code **01092110000000**

kit order code **01092110000000**

		mm (inch)			
		A	B	C	
2SP...8	+ 1SPA	9.8	48.2 (1.896)	168.9 (6.652)	225.1 (8.862)
		7.8	48.2 (1.896)	165.0 (6.496)	217.2 (8.551)
		6.3	48.2 (1.896)	162.2 (6.384)	211.5 (8.327)
		5	48.2 (1.896)	159.6 (6.283)	206.4 (8.126)
		4.2	48.2 (1.896)	158.1 (6.222)	203.3 (8.004)
		3.7	48.2 (1.896)	157.1 (6.185)	201.4 (7.929)
		3.2	48.2 (1.896)	156.1 (6.146)	199.4 (7.850)
		2.5	48.2 (1.896)	154.8 (6.093)	196.7 (7.744)
		2	48.2 (1.896)	153.8 (6.053)	194.7 (7.665)
		1.6	48.2 (1.896)	153.0 (6.024)	193.2 (7.606)
		1.2	48.2 (1.896)	152.2 (5.990)	191.5 (7.539)
		0.9	48.2 (1.896)	151.6 (5.969)	190.4 (7.496)
2SP...6	+ 1SPA	9.8	46.1 (1.813)	164.8 (6.486)	220.9 (8.697)
		7.8	46.1 (1.813)	160.8 (6.331)	213.0 (8.386)
		6.3	46.1 (1.813)	157.9 (6.219)	207.3 (8.161)
		5	46.1 (1.813)	155.4 (6.118)	202.2 (7.961)
		4.2	46.1 (1.813)	153.9 (6.057)	199.1 (7.839)
		3.7	46.1 (1.813)	152.9 (6.020)	197.2 (7.764)
		3.2	46.1 (1.813)	151.9 (5.980)	195.2 (7.685)
		2.5	46.1 (1.813)	150.6 (5.927)	192.5 (7.579)
		2	46.1 (1.813)	149.6 (5.888)	190.5 (7.500)
		1.6	46.1 (1.813)	148.8 (5.858)	189.0 (7.441)
		1.2	46.1 (1.813)	147.9 (5.825)	187.3 (7.374)
		0.9	46.1 (1.813)	147.4 (5.803)	186.2 (7.331)

		mm (inch)			
		A	B	C	
2SP...4	+ 1SPA	9.8	44.4 (1.748)	168.9 (6.652)	217.6 (8.567)
		7.8	44.4 (1.748)	194.1 (7.642)	209.7 (8.256)
		6.3	44.4 (1.748)	191.3 (7.530)	204.0 (8.032)
		5	44.4 (1.748)	188.7 (7.429)	198.9 (7.831)
		4.2	44.4 (1.748)	187.2 (7.368)	195.8 (7.709)
		3.7	44.4 (1.748)	186.2 (7.331)	193.9 (7.634)
		3.2	44.4 (1.748v)	185.2 (7.291)	191.9 (7.555)
		2.5	44.4 (1.748)	183.9 (7.238)	189.2 (7.449)
		2	44.4 (1.748)	182.9 (7.199)	187.2 (7.370)
		1.6	44.4 (1.748)	182.1 (7.169)	185.7 (7.311)
		1.2	44.4 (1.748)	181.3 (7.136)	184.0 (7.244)
		0.9	44.4 (1.748)	180.7 (7.114)	182.9 (7.201)

With B80C flange increase A, B, and C dimensions of 0.079 inch
 With E52C flange decrease A, B, and C dimensions of 0.106 inch

SEE PAGE 301 FOR PRICES

Definition of pressures

The pumps can be subjected to the pressures P1, P2 or P3 indicated in the performance tables. The following diagram illustrates the definitions and applicability of these, compared to the rotation speed limits included.

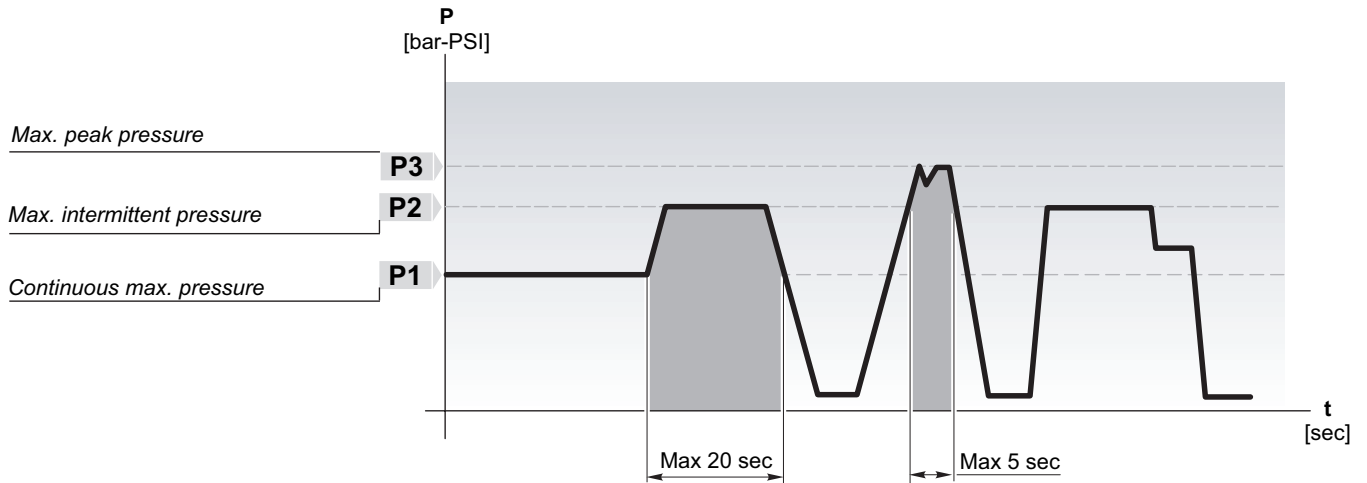

Hydraulic measures

Q Flow	[l/min - Gal/min]
M Torque	[Nm - lbf.in]
P Power	[kW - HP]
V Displacement	[cm ³ /rev - in ³ /rev]
N Speed	[min ⁻¹ - rpm]
Δp Pressure	[bar - PSI]

η_v Volumetric efficiency

η_m Mechanical efficiency

Useful formulas

$$Q = V [\text{cm}^3/\text{rev}] \times \eta_v \times n \cdot 10^{-3} \quad \text{l/min}$$

$$M = \frac{\Delta p [\text{bar}] \times V [\text{cm}^3/\text{rev}]}{62.83 \times \eta_m} \quad \text{Nm}$$

$$P = \frac{\Delta p [\text{bar}] \times V [\text{cm}^3/\text{rev}] \times n}{600 \times 1000 \times \eta_t} \quad \text{kW}$$

Conversion factors

1 l/min = 0.2641 US Gal/min
1 Nm = 8.851 in-lbs
1 Nm = 0.7375 ft-lbs
1 N = 0.2248 lbs
1kW = 1.34 HP
1cm ³ /giro = 0.061 in ³ /rev
1 bar = 14.5 PSI
1 mm = 0.0394 in
1 kg = 2.205 lbs

Hydraulic fluids

It is advisable to use hydraulic oils of mineral origin with anti-foaming, anti-oxidant and anti-corrosion characteristics and a high viscosity index;

- Recommended viscosity $15 \div 92 \text{ mm}^2/\text{s}$ (cSt)
- Start-up viscosity limit $3000 \text{ mm}^2/\text{s}$ (cSt)

During normal operation, the temperature of the oil must be between 20°C and 65°C and limit values between -15°C and 80°C .

Suction pressure

The allowed working pressure supplied must be in the range $0.7 - 3 \text{ bar}$ (absolute).

For higher values (up to 30 bar), versions with a K seal must be used.

Suction and delivery pipes

Particular attention must be given to the sizing of pipes (rigid or flexible), avoiding disproportionate lengths, sudden variations in cross section or small curvature radius, in any case selecting pipe cross-sections that guarantee an oil speed between 0.6 and 12 m/s .

Filtration

In order to eliminate any impurities present in the oil and to guarantee a longer duration of the pump, the system must be equipped with effective filtration which must be periodically checked to ensure that it is operating correctly.

The following are the recommended filtration levels:

- $26/23 \text{ ISO DIS 4406}$ up to 150 bar
- $23/20 \text{ ISO DIS 4406}$ for higher pressures.

Installation notes

- Make sure that the coupling used for pulling compensates for any axial misalignments that could compromise the integrity of the pump.
- If there are radial and/or axial/ loads on the pump shaft (as is the case, for example, when pulling is carried out using pulleys and belts) the versions available with a support must be chosen.
- The connection coupling between spline shafts must be appropriately lubricated, free to move axially and of an adequate length to cover the entire extension of the two shafts (motor and pump).
- If the pump is painted, protect the shaft seal and also make sure that the contact zone between the shaft seal and the shaft is free of dust or abrasive sediments.

Rotation direction

The rotation direction is defined as S (left/anticlockwise) or D (right/clockwise) by observing the shaft from the front.

The pumps are monodirectional and therefore when ordering the required rotation direction must be specified; alternatively it is possible to modify the internal set-up as illustrated below (inversion of the rotation direction).

The pages regarding the pump characteristics highlight the directions of the delivery and suction flows for each version and rotation direction.

Pressure drops

The following nomogram allows you to calculate the pressure drops for each 100 m of piping when the viscosity of the oil, the delivery capacity of the pump and the diameter of the piping are known.

The viscosity (V), flow capacity (Q) and diameter (D) values are fixed on the respective scales; a line is drawn joining the points V and Q; the point where this intersects the index line is defined as point I. If the line joining point I to point D is extended, the load pressure drops value can then be read at the intersection with the last scale.

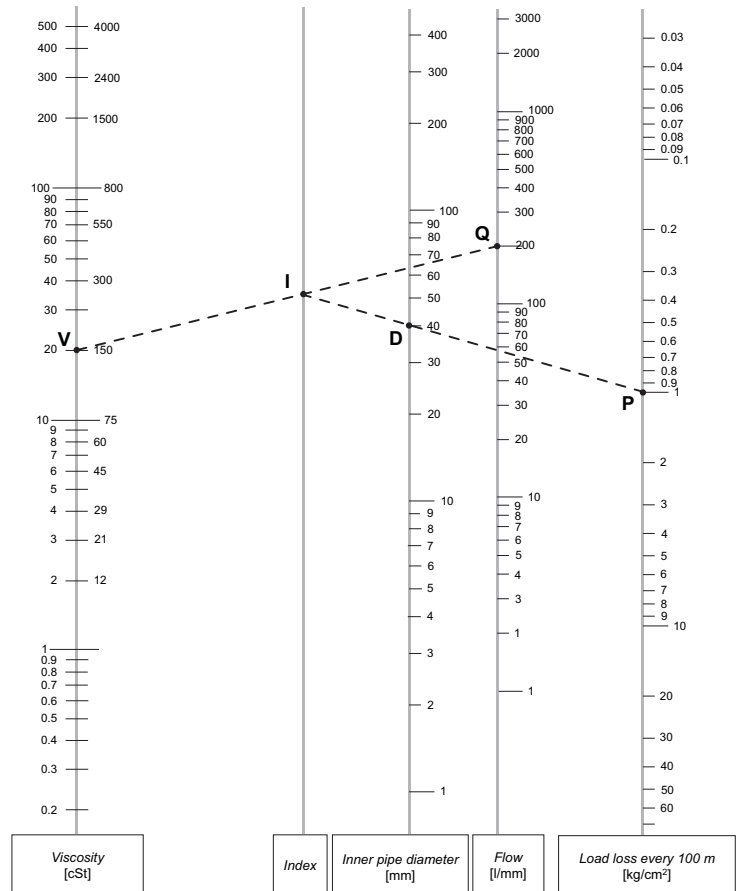

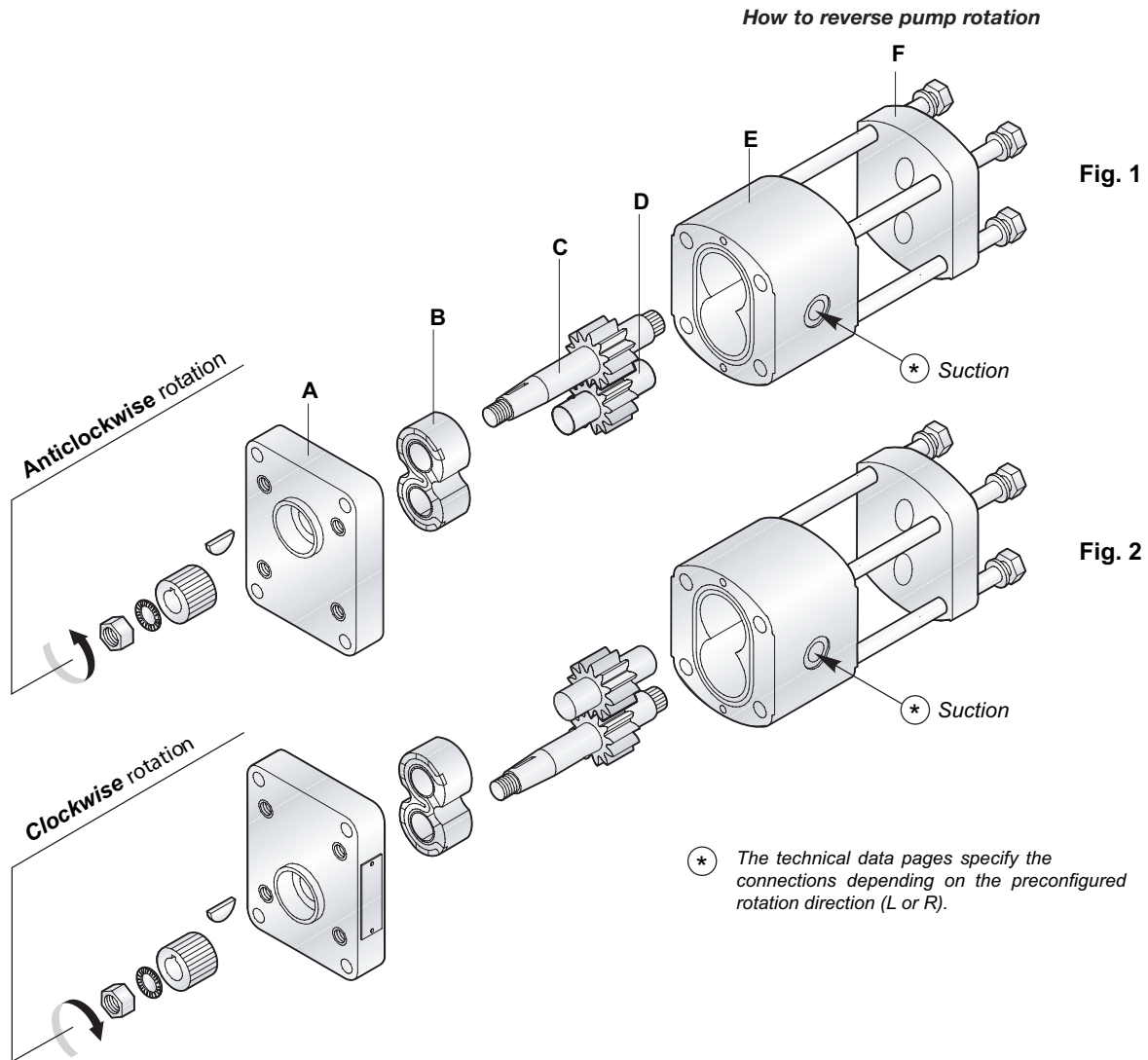

The gear pumps direction of rotation is indicated by an arrow on the label.

How to reverse the pumps rotation:

- Disassemble pump as shown in figure 1.
- Pull off gears C - D and reassemble according to figure 2.
- Reassemble bushing B as before.
- Reverse the flange A and reassemble the pump tightening the screws by using a torque wrench.
- For the pumps GR3 - GR4, disassemble only front flange.

Type of pump	GR1	GR2	GR3	GR4
Numbers of screws	4	4	16	16
Type of threads	M8	M10	M10	M14
Tightening torque of screws	30 Nm (266 in-lbs)	50 Nm (443 in-lbs)	60 Nm (531 in-lbs)	140 Nm (1239 in-lbs)
Type of coupling	1IS 12M	2IS 14M 2IS 15M	3IS 18M	4IS 23M
Tightening torque at nut coupling	9 ÷ 10 Nm (80 ÷ 89 in-lbs)	22 ÷ 25 Nm (195 ÷ 221 in-lbs) 32 ÷ 35 Nm (283 ÷ 310 in-lbs)	50 ÷ 55 Nm (443 ÷ 487 in-lbs)	100 ÷ 120 Nm (885 ÷ 1062 in-lbs)

Flow - Speed chart

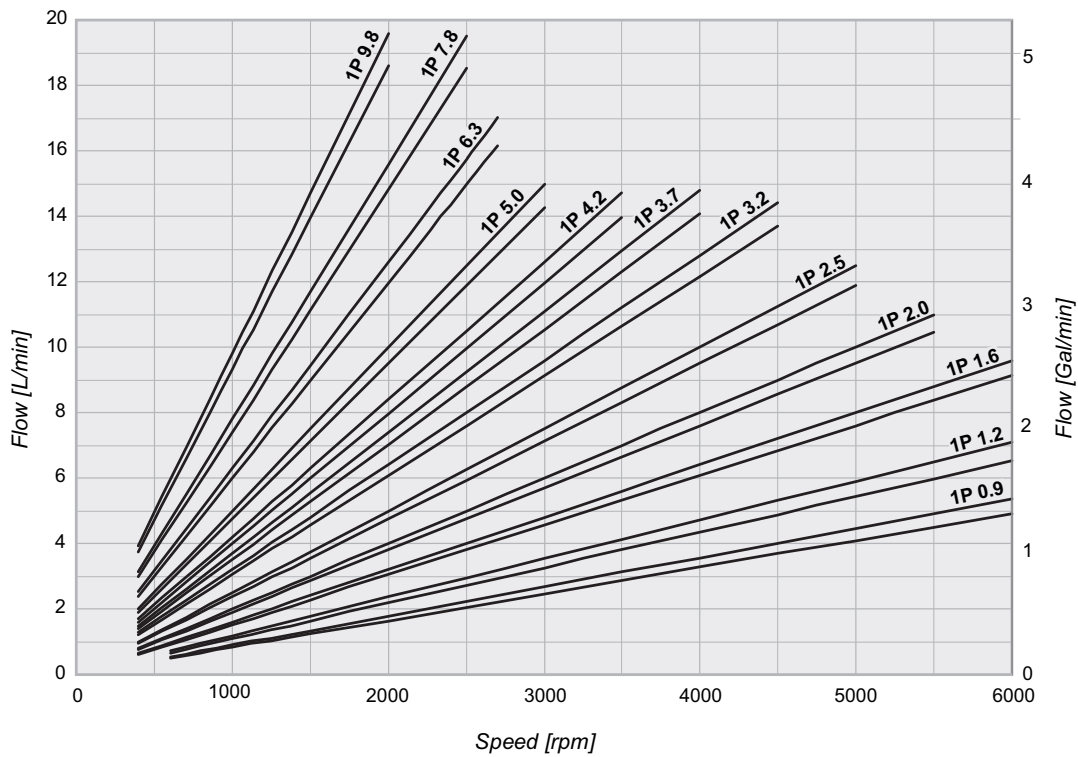

Pumps Group 1 Power and Speed Diagrams

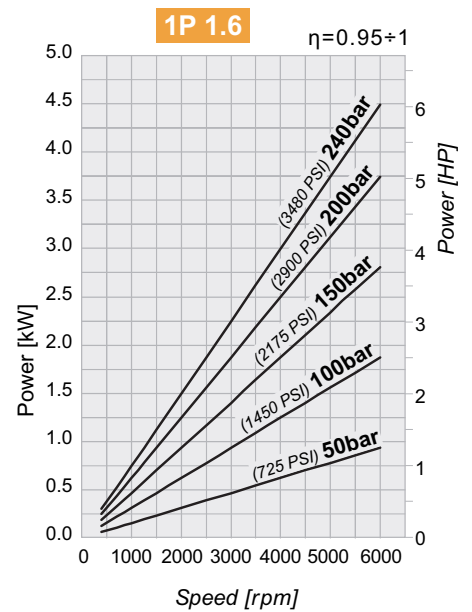
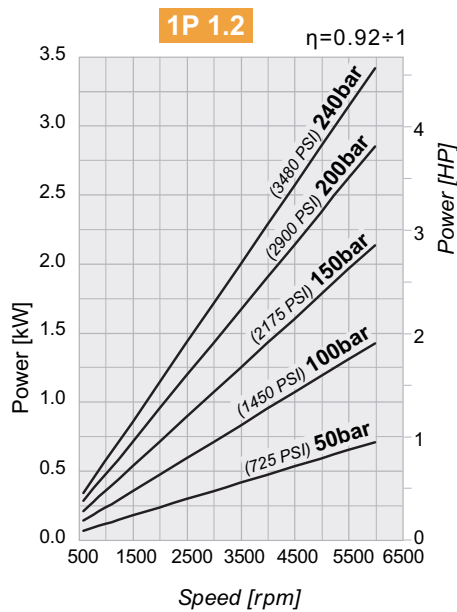
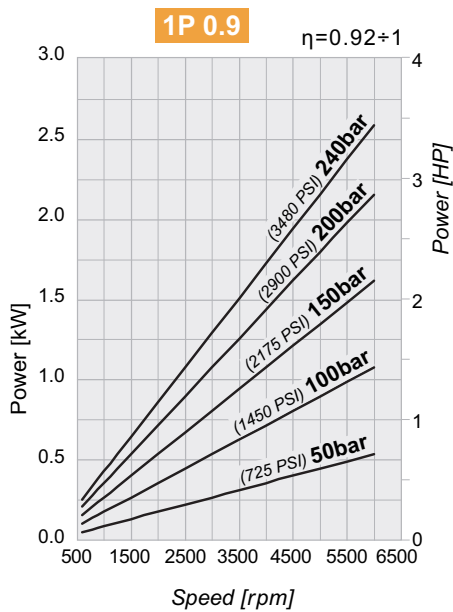

PUMPS GROUP 1 • PERFORMANCE



Pumps Group 1 Power and Speed Diagrams

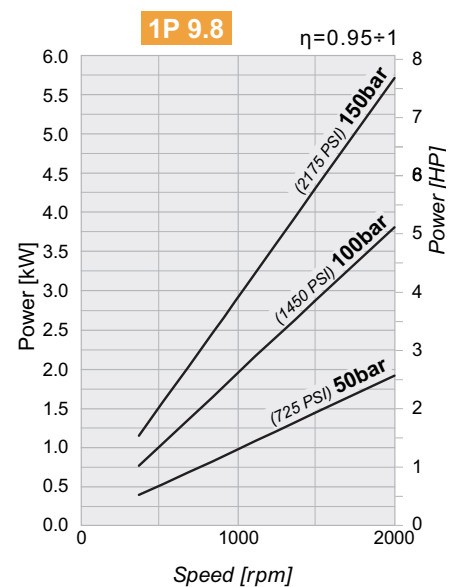
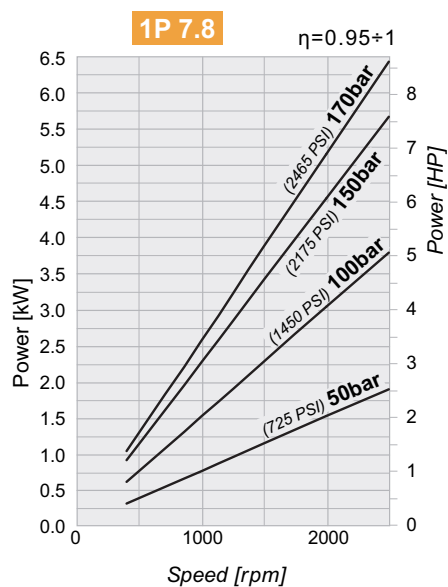
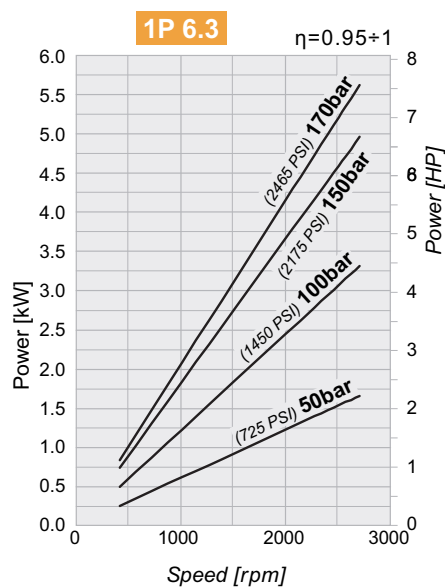
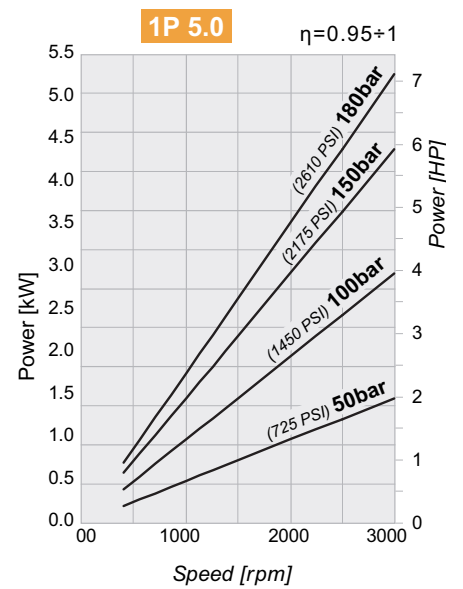
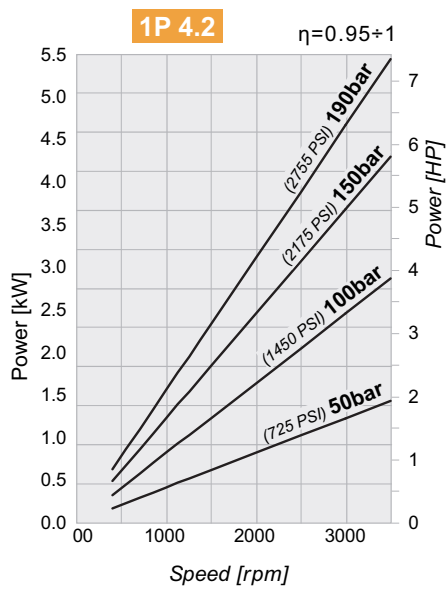
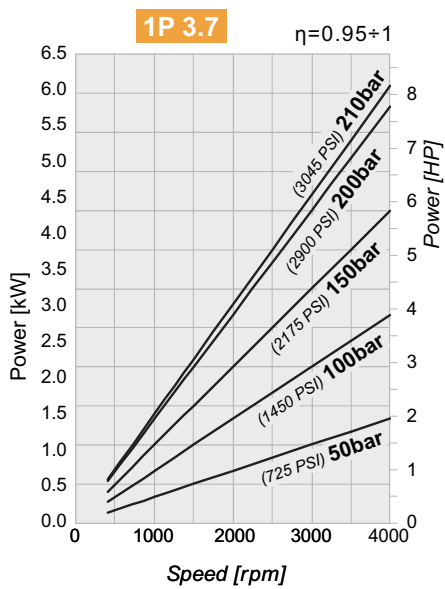
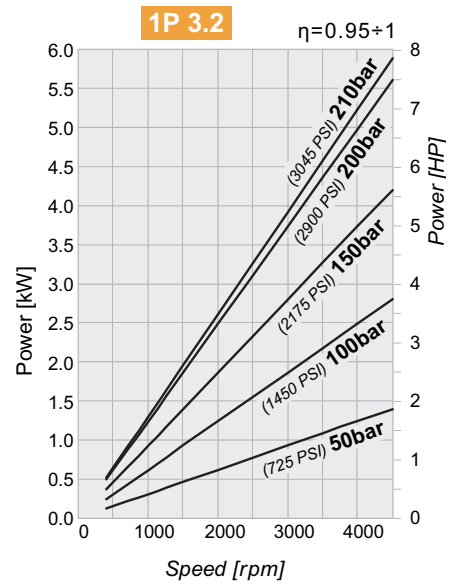
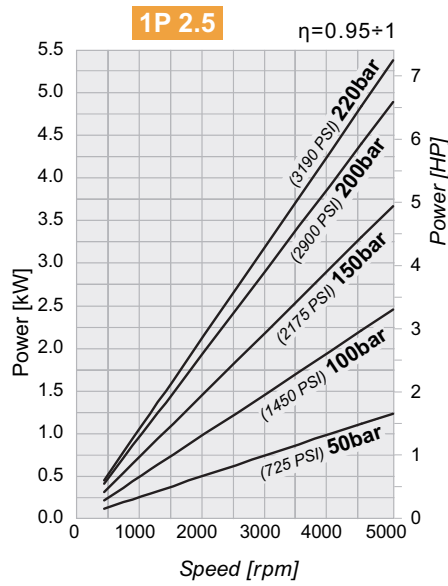
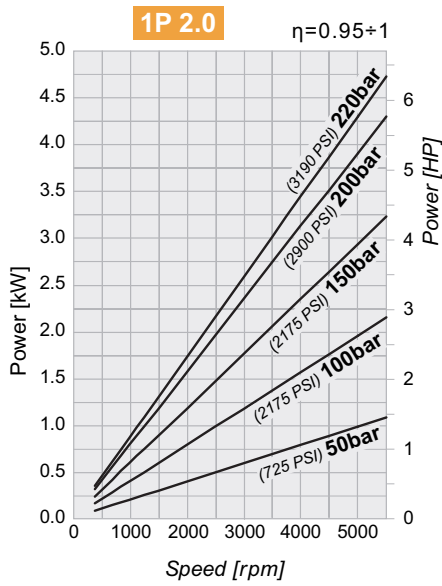

Flow - Speed chart

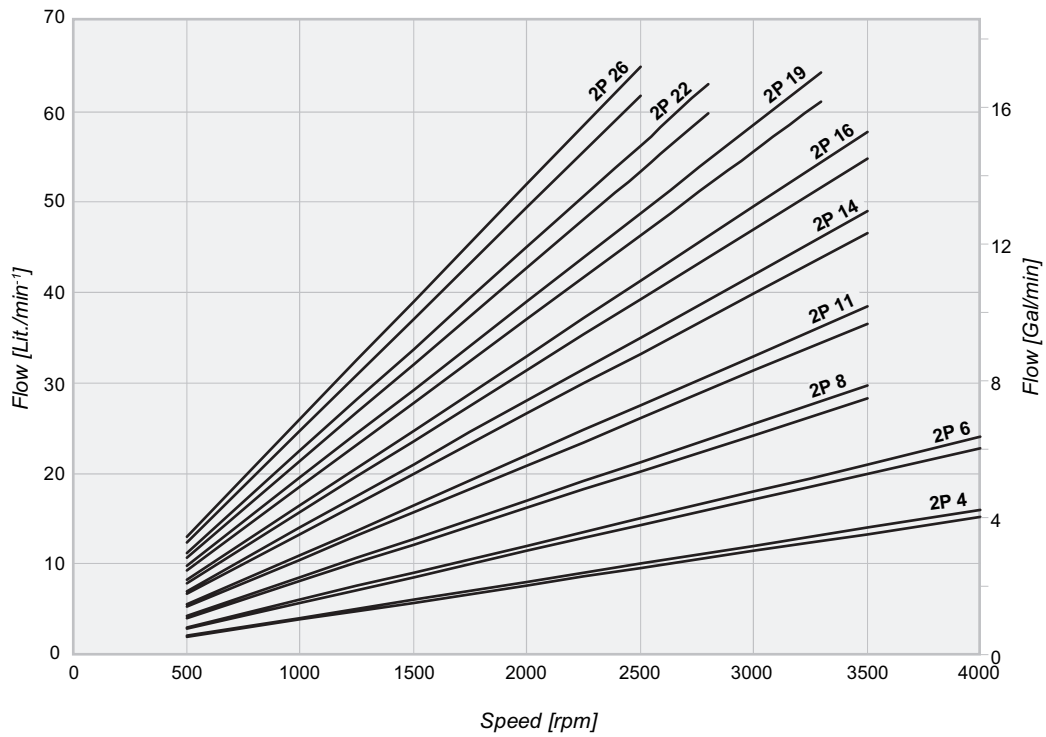

Pumps Group 2 Power and Speed Diagrams

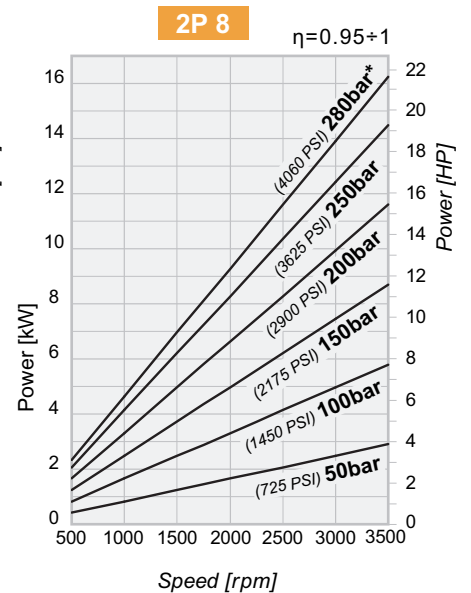
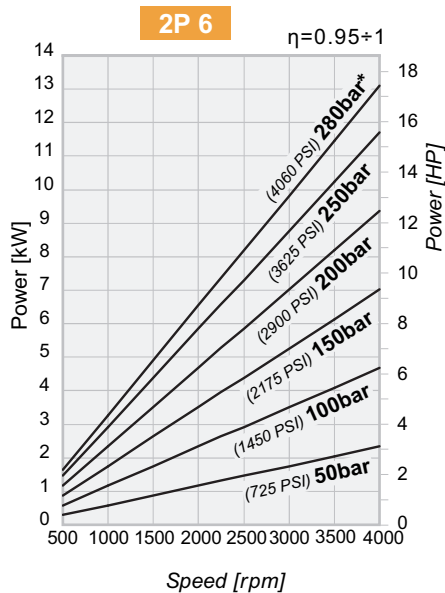
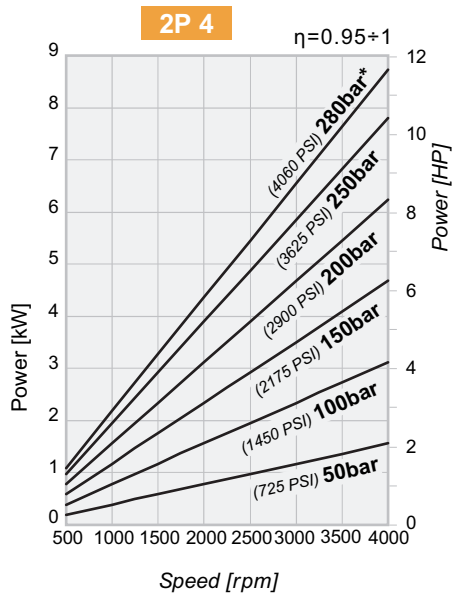

* Only for cast iron pumps

Pumps Group 2 Power and Speed Diagrams

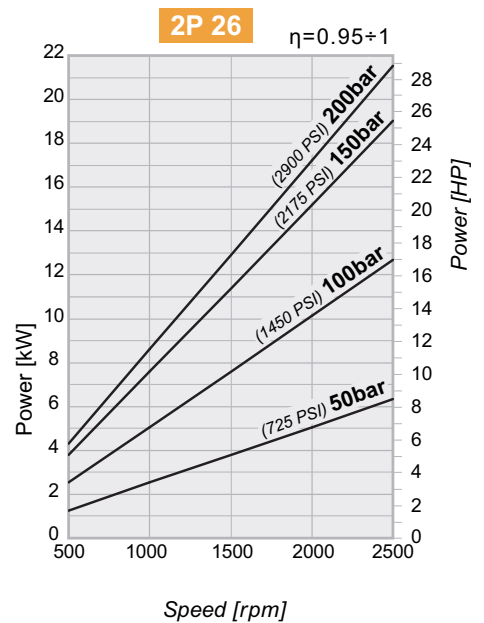
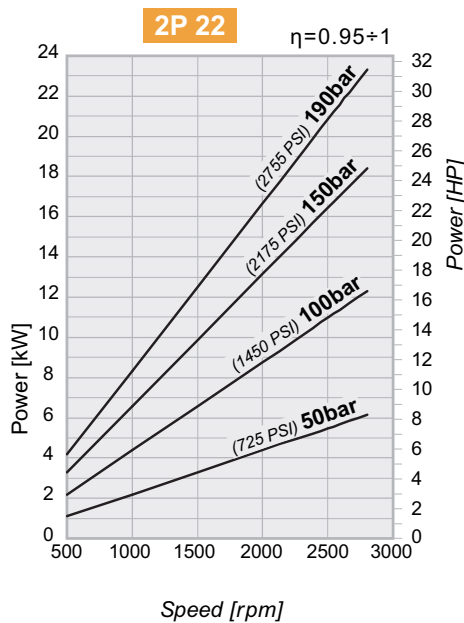
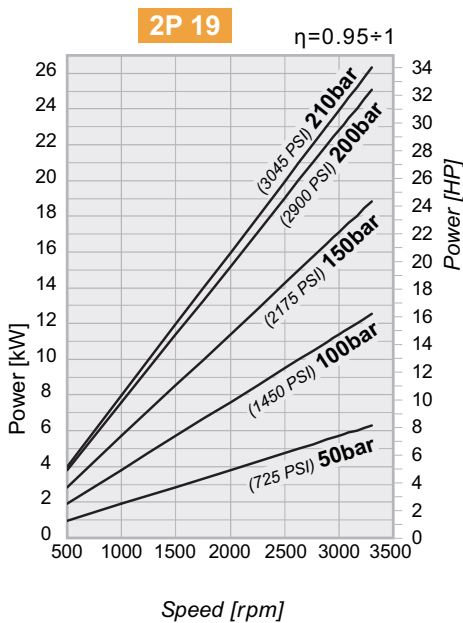
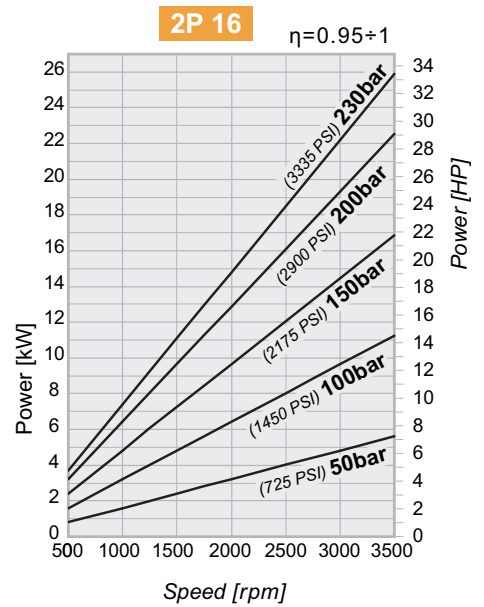
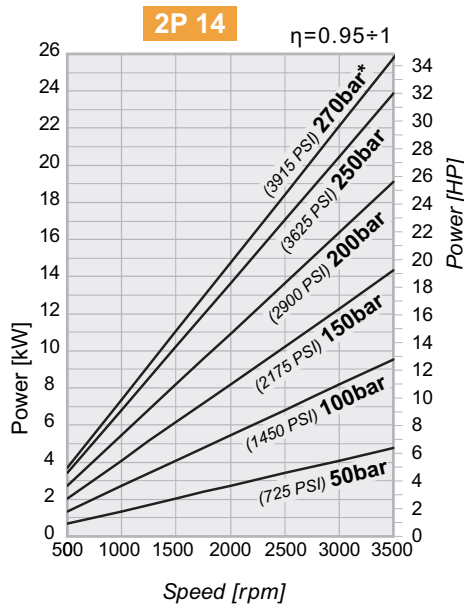
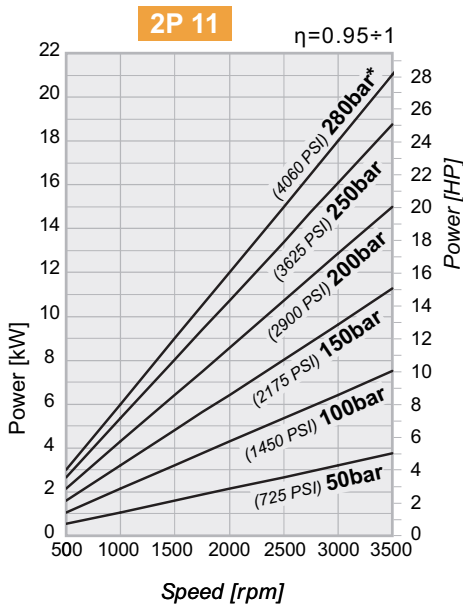

PUMPS GROUP 1 • STANDARD



Technical data

Size	Displacement [cm ³ /rev] (in ³ /rev)	Max. working pressure			Max. speed [g/min] (rpm)	Max. flow [l/min] (Gal/min)	Min. speed [g/min] (rpm)	Min. flow [l/min] (Gal/min)	Dimensions		Mass [Kg] (lbs)	Min. volumetric efficiency %
		P1 [bar] (PSI)	P2 [bar] (PSI)	P3 [bar] (PSI)					A [mm] (inch)	B [mm] (inch)		
1SP A0.9	0.89 (0.05)	240 (3480)	260 (3770)	290 (4205)	6000	5.3 (1.40)	600	0.49 (0.13)	34.80 (1.370)	73.6 (2.898)	0.91 (2.01)	92*
1SP A1.2	1.18 (0.07)	240 (3480)	260 (3770)	290 (4205)	6000	7.1 (1.88)	600	0.65 (0.17)	35.35 (1.392)	74.7 (2.941)	0.93 (2.05)	
1SP A1.6	1.6 (0.10)	240 (3480)	260 (3770)	290 (4205)	6000	9.6 (2.54)	400	0.61 (0.16)	36.20 (1.425)	76.4 (3.008)	0.95 (2.09)	
1SP A2.0	2.0 (0.12)	220 (3190)	250 (3625)	270 (3915)	5500	11 (2.91)	400	0.76 (0.20)	36.95 (1.455)	77.9 (3.067)	0.97 (2.14)	95*
1SP A2.5	2.5 (0.15)	220 (3190)	250 (3625)	270 (3915)	5000	12.5 (3.30)	400	0.95 (0.25)	37.95 (1.494)	79.9 (3.146)	1.00 (2.21)	
1SP A3.2	3.2 (0.20)	210 (3045)	240 (3480)	260 (3770)	4500	14.4 (3.80)	400	1.21 (0.32)	39.30 (1.547)	82.6 (3.252)	1.04 (2.29)	
1SP A3.7	3.7 (0.23)	210 (3045)	240 (3480)	260 (3770)	4000	14.8 (3.91)	400	1.40 (0.37)	40.30 (1.587)	84.6 (3.331)	1.07 (2.36)	
1SP A4.2	4.2 (0.26)	190 (2755)	210 (3045)	230 (3335)	3500	14.7 (3.88)	400	1.60 (0.42)	41.25 (1.624)	86.5 (3.406)	1.10 (2.43)	
1SP A5.0	5.0 (0.31)	180 (2610)	210 (3045)	230 (3335)	3000	15 (3.96)	400	1.90 (0.50)	42.80 (1.685)	89.6 (3.528)	1.14 (2.51)	
1SP A6.3	6.3 (0.38)	170 (2465)	190 (2755)	210 (3045)	2700	17 (4.49)	400	2.39 (0.63)	45.35 (1.785)	94.7 (3.728)	1.22 (2.69)	
1SP A7.8	7.76 (0.47)	170 (2465)	190 (2755)	210 (3045)	2500	19.4 (5.13)	400	2.95 (0.78)	48.20 (1.898)	100.4 (3.953)	1.30 (2.87)	
1SP A9.8	9.78 (0.60)	150 (2175)	170 (2465)	190 (2755)	2000	19.6 (5.18)	400	3.71 (0.98)	52.15 (2.053)	108.3 (4.264)	1.41 (3.11)	

* Value collected during the testing at 1500 rpm

Example of ordering code

1SP	A	2.0	D	(H)	-	10	GG	0	(VT)
-----	---	-----	---	-----	---	----	----	---	------

1SP	Pump type	see table
A	Flange and cover material	A = Aluminium
2.0	Displacement	see table
D	Clockwise rotation	D = Clockwise rotation S = Anticlockwise rotation
(H)	Stiffening seal for low suction pressure	(optional)
— ⁽¹⁾	Standard flange	
10	Shaft type	10 - 11 - 13 - 14 - 15 - 27
GG	Port connection type	GG - NN - TT - UU - NG - TG - UG
0	Connections positions	0 - 1 - 3 - 4
(VT)	Optional	(VT) Viton seals (optional) VLP-I (N) Pressure relief valve (page A-27)

⁽¹⁾ It is not necessary to indicate STANDARD flange

Conn Port Connections

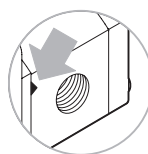
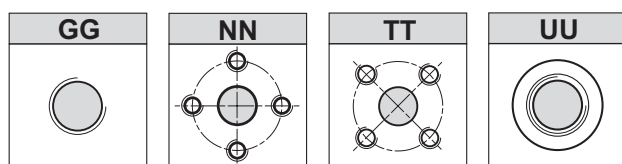

The sign on the body identifies the **suction side** for the pumps.

Connection positions

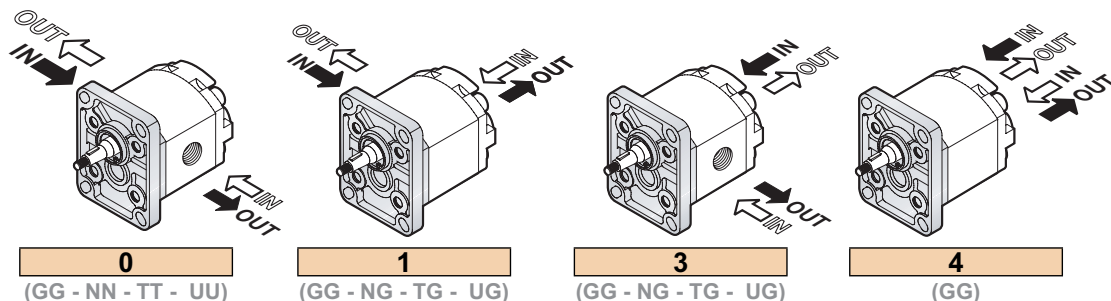

Rotation	
D	S

SEE PAGE 285 FOR PRICES

Dimensions mm (inch)

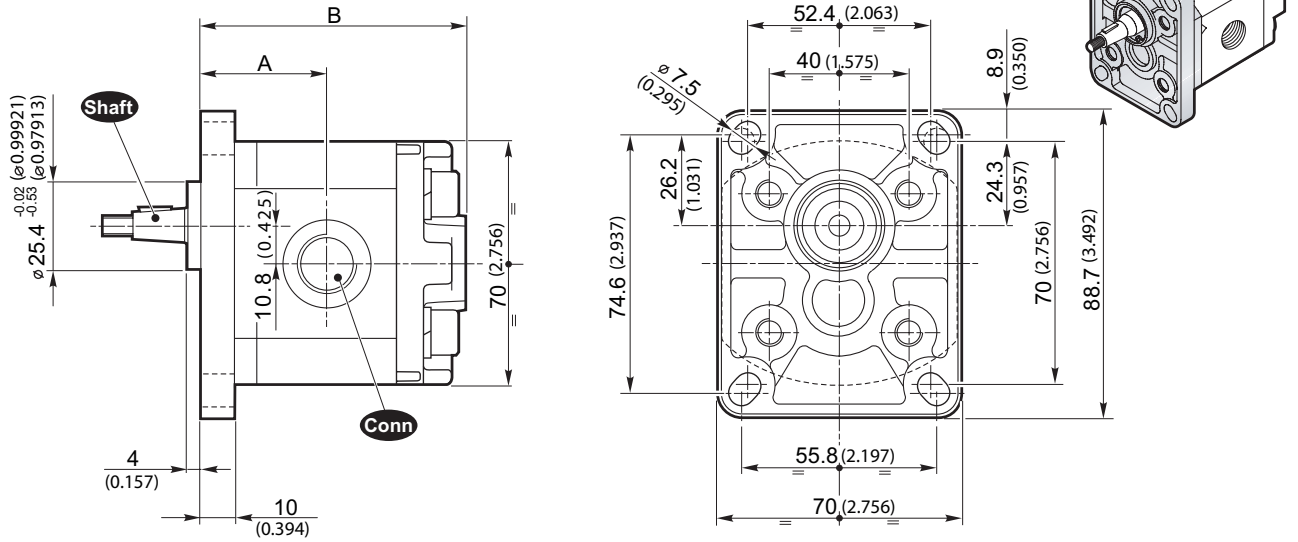

Shaft Available shafts

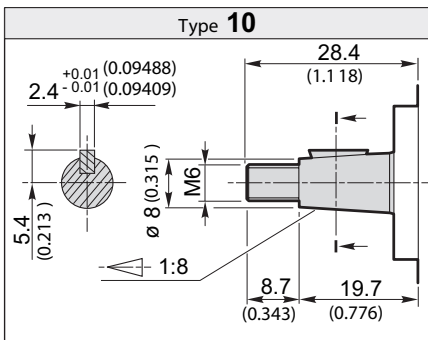

Torque 18 Nm / 13.3 ft-lbs

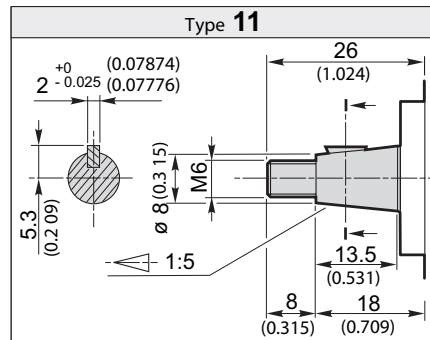

Torque 18 Nm / 13.3 ft-lbs

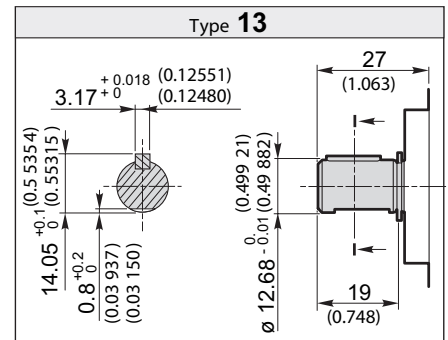

Torque 30 Nm / 22.1 ft-lbs

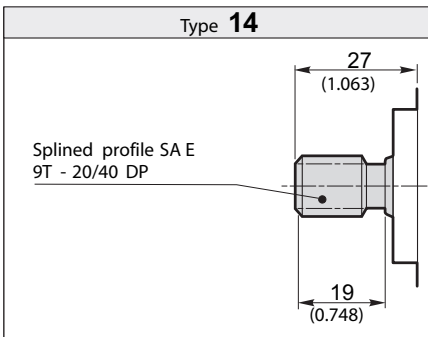

Torque 30 Nm / 22.1 ft-lbs

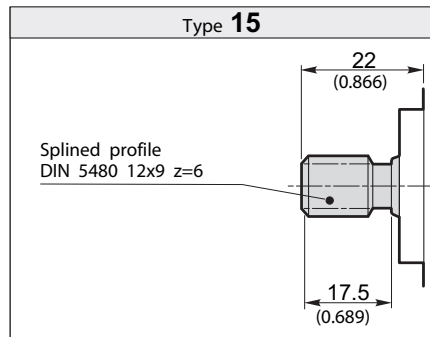

Torque 30 Nm / 22.1 ft-lbs

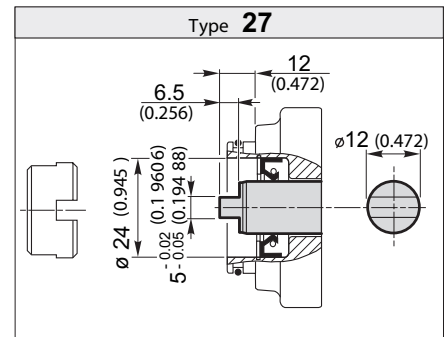

Torque 12 Nm / 8.9 ft-lbs

SEE PAGE 247 FOR PORT SIZES AVAILABLE

SEE PAGE 285 FOR PRICES

Technical data

Size	Displacement [cm ³ /rev] (in ³ /rev)	Max. working pressure			Max. speed [g/min] (rpm)	Max. flow [*] [l/min] (Gal/min)	Min. speed [g/min] (rpm)	Min. flow [l/min] (Gal/min)	Dimensions		Mass [Kg] (lbs)	Min. volumetric efficiency %
		P1 [bar] (PSI)	P2 [bar] (PSI)	P3 [bar] (PSI)					A [mm] (inch)	B [mm] (inch)		
1SP A0.9	0.89 (0.05)	240 (3480)	260 (3770)	290 (4205)	6000	5.3 (1.40)	600	0.49 (0.13)	38.3 (1.508)	77.1 (3.035)	0.91 (2.01)	92*
1SP A1.2	1.18 (0.07)	240 (3480)	260 (3770)	290 (4205)	6000	7.1 (1.88)	600	0.65 (0.17)	38.85 (1.530)	78.2 (3.079)	0.93 (2.05)	
1SP A1.6	1.6 (0.10)	240 (3480)	260 (3770)	290 (4205)	6000	9.6 (2.54)	400	0.61 (0.16)	39.7 (1.563)	79.9 (3.146)	0.95 (2.09)	
1SP A2.0	2.0 (0.12)	220 (3190)	250 (3625)	270 (3915)	5500	11 (2.91)	400	0.76 (0.20)	40.45 (1.593)	81.4 (3.205)	0.97 (2.14)	95*
1SP A2.5	2.5 (0.15)	220 (3190)	250 (3625)	270 (3915)	5000	12.5 (3.30)	400	0.95 (0.25)	41.45 (1.632)	83.4 (3.283)	1.00 (2.21)	
1SP A3.2	3.2 (0.20)	210 (3045)	240 (3480)	260 (3770)	4500	14.4 (3.80)	400	1.21 (0.32)	42.8 (1.685)	86.1 (3.390)	1.04 (2.29)	
1SP A3.7	3.7 (0.23)	210 (3045)	240 (3480)	260 (3770)	4000	14.8 (3.91)	400	1.40 (0.37)	43.8 (1.724)	88.1 (3.469)	1.07 (2.369)	
1SP A4.2	4.2 (0.26)	190 (2755)	210 (3045)	230 (3335)	3500	14.7 (3.88)	400	1.60 (0.42)	44.75 (1.762)	90 (3.543)	1.10 (2.43)	
1SP A5.0	5.0 (0.31)	180 (2610)	210 (3045)	230 (3335)	3000	15 (3.96)	400	1.90 (0.50)	46.3 (1.823)	93.1 (3.665)	1.14 (2.51)	
1SP A6.3	6.3 (0.38)	170 (2465)	190 (2755)	210 (3045)	2700	17 (4.49)	400	2.39 (0.63)	48.85 (1.923)	98.2 (3.866)	1.22 (2.69)	
1SP A7.8	7.76 (0.47)	170 (2465)	190 (2755)	210 (3045)	2500	19.4 (5.13)	400	2.95 (0.78)	51.7 (2.035)	103.9 (4.091)	1.30 (2.87)	
1SP A9.8	9.78 (0.60)	150 (2175)	170 (2465)	190 (2755)	2000	19.6 (5.18)	400	3.71 (0.98)	55.65 (2.191)	111.8 (4.402)	1.41 (3.11)	

* Value collected during the testing at 1500 rpm

Example of ordering code

1SP	A	2.0	D	SAE AA	(H)	10	GG	0	(VT)
-----	---	-----	---	--------	-----	----	----	---	------

1SP	Pump type	see table
A	Flange and cover material	A = Aluminium
2.0	Displacement	see table
D	Clockwise rotation	D = Clockwise rotation S = Anticlockwise rotation
SAE AA	Flange type	SAE AA
(H)	Stiffening seal for low suction pressure	(optional)
—		
10	Shaft type	10 - 11 - 13 - 14 - 15 - 27
GG	Connections type	GG - NN - TT - UU - NG - TG - UG
0	Connections positions	0 - 1 - 3 - 4
(VT)	Optional	(VT) Viton seals (optional) VLP-I (N) Pressure relief valve (page A-27)

Conn Port Connections

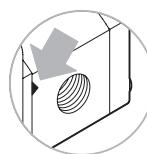
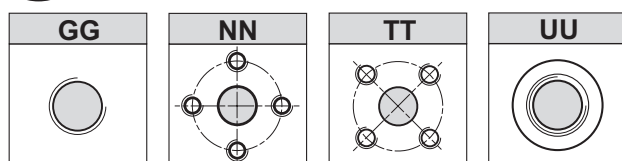

The sign on the body identifies the **suction side** for the pumps.

Port Connection positions

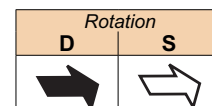
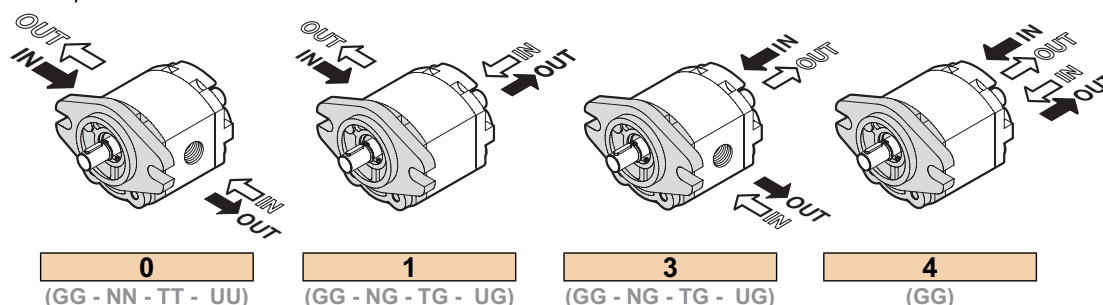

SEE PAGE 285 FOR PRICES

Dimensions

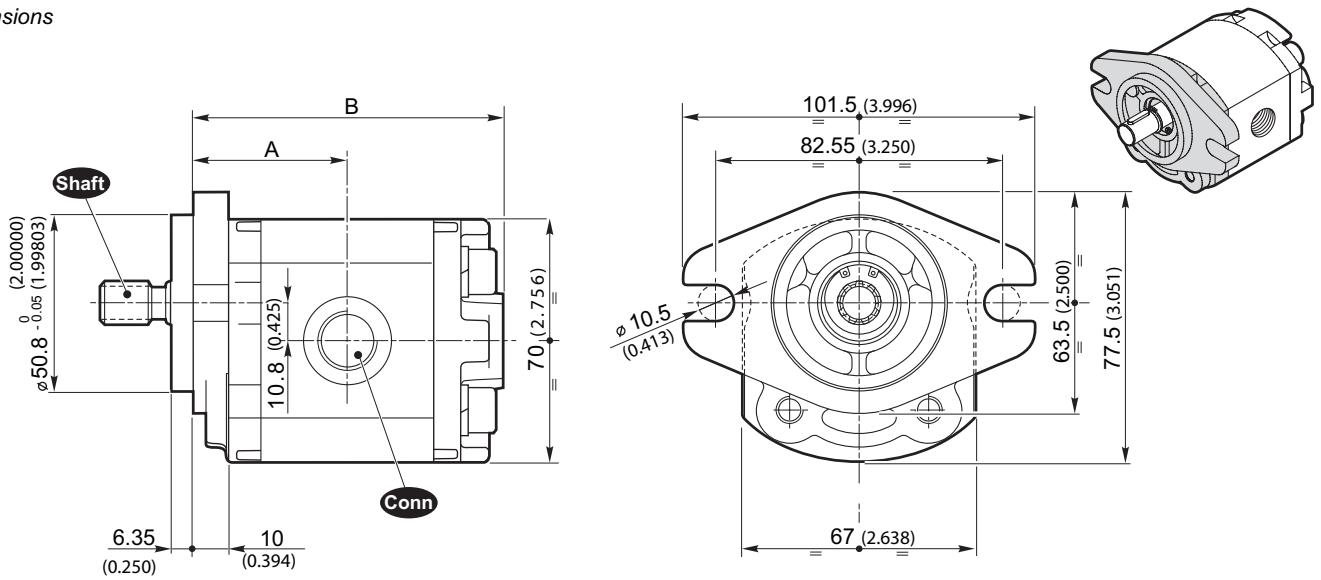

Shaft Available shafts

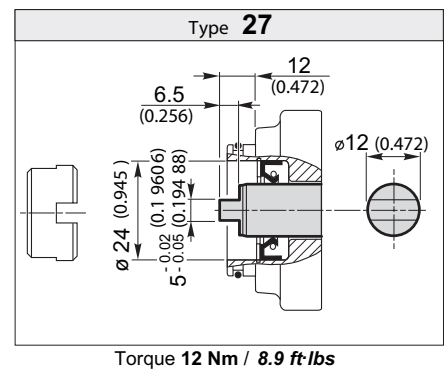
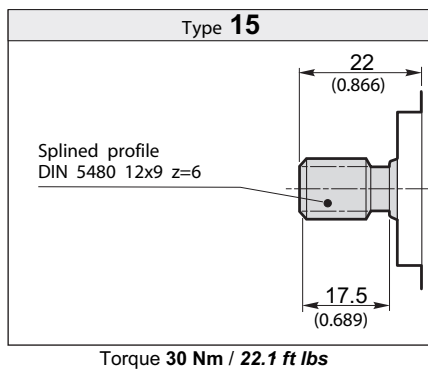
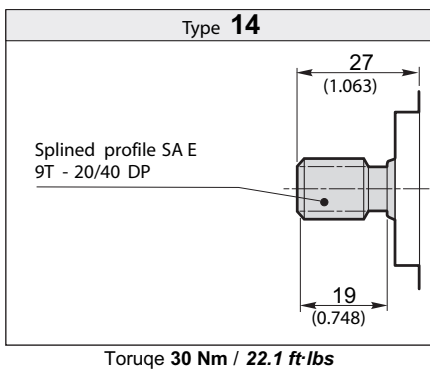
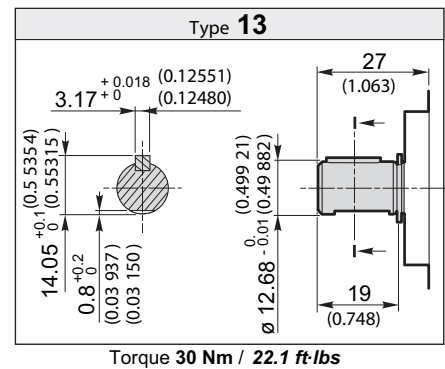
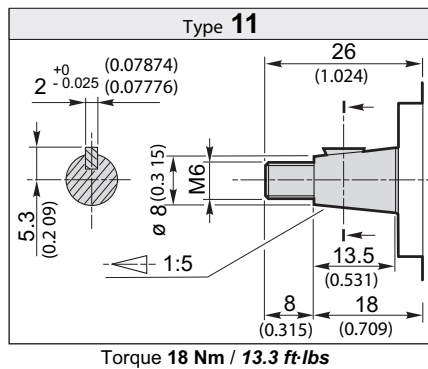
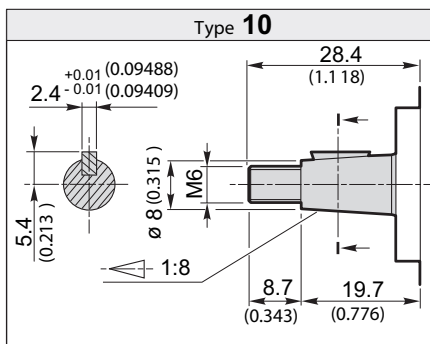

SEE PAGE 247 FOR PORT SIZES AVAILABLE

SEE PAGE 285 FOR PRICES

Technical data

Power-pack

Size	Displacement [cm ³ /rev] (in ³ /rev)	Max. working pressure			Max. speed [g/min] (rpm)	Max. flow [lt/min] (Gal/min)	Min. speed [g/min] (rpm)	Min. flow [lt/min] (Gal/min)	Dimensions			Mass [Kg] (lbs)	Min. volumetric efficiency %
		P1	P2	P3					A	B	L ①		
		[bar] (PSI)	[bar] (PSI)	[bar] (PSI)					[mm] (inch)	[mm] (inch)	[mm] (inch)		
1SP A0.9	0.89 (0.05)	210 (3045)	240 (3480)	260 (3770)	6000	5.3 (1.40)	600	0.49 (0.13)	73.1 (2.878)	61.6 (2.425)	80 (3.150)	0.91 (2.01)	92*
1SP A1.2	1.18 (0.07)	210 (3045)	240 (3480)	260 (3770)	6000	7.1 (1.88)	600	0.65 (0.17)	74.2 (2.921)	62.7 (2.469)	80 (3.150)	0.93 (2.05)	
1SP A1.6	1.6 (0.10)	210 (3045)	240 (3480)	260 (3770)	6000	9.6 (2.54)	400	0.61 (0.16)	75.9 (2.988)	64.4 (2.535)	80 (3.150)	0.95 (2.09)	
1SP A2.0	2.0 (0.12)	210 (3045)	240 (3480)	260 (3770)	5500	11 (2.91)	400	0.76 (0.20)	77.4 (3.047)	65.9 (2.594)	80 (3.150)	0.97 (2.14)	95*
1SP A2.5	2.5 (0.15)	210 (3045)	240 (3480)	260 (3770)	5000	12.5 (3.30)	400	0.95 (0.25)	79.4 (3.126)	67.9 (2.673)	85 (3.346)	1.00 (2.21)	
1SP A3.2	3.2 (0.20)	200 (2900)	230 (3335)	250 (3625)	4500	14.4 (3.80)	400	1.21 (0.32)	82.1 (3.232)	70.6 (2.780)	85 (3.346)	1.04 (2.29)	
1SP A3.7	3.7 (0.23)	200 (2900)	230 (3335)	250 (3625)	4000	14.8 (3.91)	400	1.40 (0.37)	84.1 (3.311)	72.6 (2.858)	90 (3.543)	1.07 (2.36)	
1SP A4.2	4.2 (0.26)	180 (2610)	210 (3045)	230 (3335)	3500	14.7 (3.88)	400	1.60 (0.42)	86 (3.386)	74.5 (2.933)	90 (3.543)	1.10 (2.43)	
1SP A5.0	5.0 (0.31)	180 (2610)	210 (3045)	230 (3335)	3000	15 (3.96)	400	1.90 (0.50)	89.1 (3.508)	77.6 (3.055)	95 (3.740)	1.14 (2.51)	
1SP A6.3	6.3 (0.38)	170 (2465)	190 (2755)	210 (3045)	2700	17 (4.49)	400	2.39 (0.63)	94.2 (3.709)	82.7 (3.256)	100 (3.937)	1.22 (2.69)	
1SP A7.8	7.76 (0.47)	170 (2465)	190 (2755)	210 (3045)	2500	19.4 (5.13)	400	2.95 (0.78)	99.9 (3.933)	88.4 (3.480)	105 (4.134)	1.30 (2.87)	
1SP A9.8	9.78 (0.60)	150 (2175)	170 (2465)	190 (2755)	2000	19.6 (5.18)	400	3.71 (0.98)	107.8 (4.244)	96.3 (3.791)	115 (4.528)	1.41 (3.11)	

* Value collected during the testing at 1500 rpm

Example of ordering code

1SP	A	3.7	D	MC 32	-	27	G05	(VT)
-----	---	-----	---	-------	---	----	-----	------

1SP	Pump type	see table
A	Flange and cover material	A = Aluminium
3.7	Displacement	see table
D	Clockwise rotation	D = Clockwise rotation S = Anticlockwise rotation
MC 32	Flange type	MC 32
—		
27	Shaft type	27 - 10 - 11 - 15
G05	Connections type and position	G05 - G02 - N02 - T02 - U02
(VT)	Optional	(VT) Viton seals (optional)

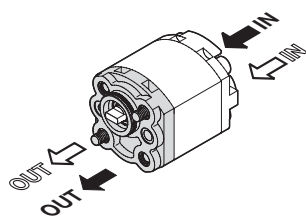

Conn Port Connections type and position

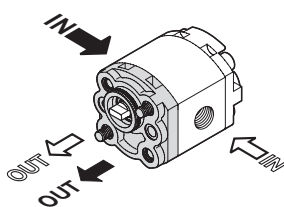

G05



**G02 - N02
T02 - U02**

Rotation	
D	S
	

SEE PAGE 285 FOR PRICES

Power-pack

Dimensions

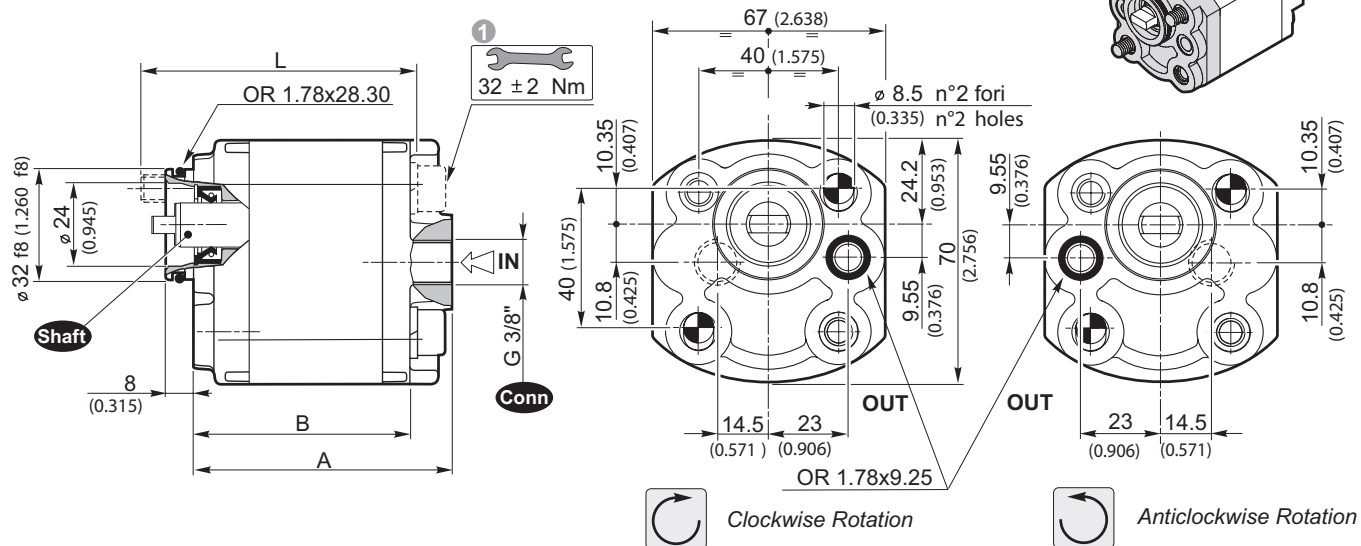

Shaft Available shafts

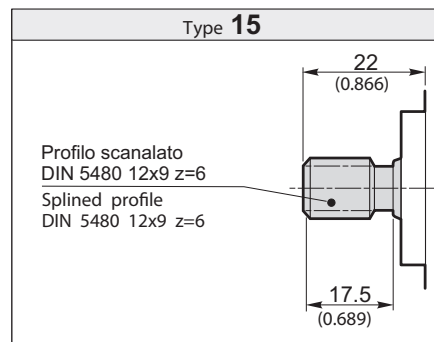
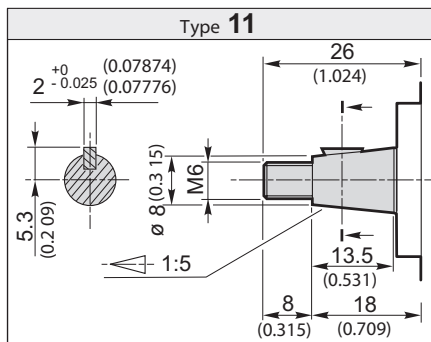
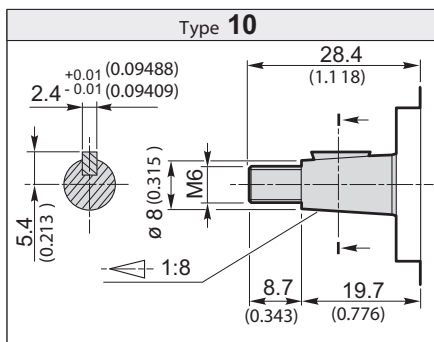

SEE PAGE 247 FOR PORT SIZES AVAILABLE

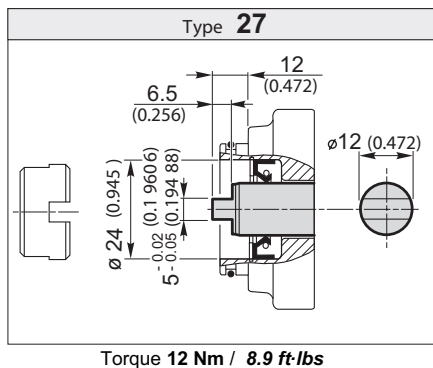

① Tightening torque of screws: 283 ± 18 lb-in. Use screws type 10.9 - 12.9 UNI EN 20898/1. The screws kit for the pump assembling should be ordered separately. Ordering code of assembling Kit:

L (see table)

The assembling of the pump should be effected by 2 screw studs type 10.9 - 12.9 pre-tighten at 221 ± 18 lb-in. Fix the pump by self-locking nuts with tightening torque 283 ± 18 lb-in.

The rotation direction shall be specified while issuing the order because this kind of operation must necessarily be carried out at our premises.

SEE PAGE 285 FOR PRICES

Technical data

(Power-pack fixing)

Size	Displacement [cm³/rev] (in³/rev)	Max. working pressure			Max. speed [g/min] (rpm)	Max. flow [lt/min] (Gal/min)	Min. speed [[g/min] (rpm)	Min. flow [lt/min] (Gal/min)	Dimensions				Mass [Kg] (lbs)	Min. volumetric efficiency %
		P1 [bar] (PSI)	P2 [bar] (PSI)	P3 [bar] (PSI)					A [mm] (inch)	B [mm] (inch)	C [mm] (inch)	L 1 [mm] (inch)		
1SP A0.9	0.89 (0.05)	210 (3045)	240 (3480)	260 (3770)	6000	5.3 (1.40)	600	0.49 (0.13)	73.6 (2.898)	34.8 (1.370)	61.6 (2.425)	80 (3.150)	0.91 (2.01)	92*
1SP A1.2	1.18 (0.07)	210 (3045)	240 (3480)	260 (3770)	6000	7.1 (1.88)	600	0.65 (0.17)	74.7 (2.941)	35.35 (1.392)	62.7 (2.469)	80 (3.150)	0.93 (2.05)	
1SP A1.6	1.6 (0.10)	210 (3045)	240 (3480)	260 (3770)	6000	9.6 (2.54)	400	0.61 (0.16)	76.4 (3.008)	36.2 (1.425)	64.4 (2.535)	80 (3.150)	0.95 (2.09)	95*
1SP A2.0	2.0 (0.12)	210 (3045)	240 (3480)	260 (3770)	5500	11 (2.91)	400	0.76 (0.20)	77.9 (3.067)	36.95 (1.455)	65.9 (2.594)	80 (3.150)	0.97 (2.14)	
1SP A2.5	2.5 (0.15)	210 (3045)	240 (3480)	260 (3770)	5000	12.5 (3.30)	400	0.95 (0.25)	79.9 (3.146)	37.95 (1.494)	67.9 (2.673)	85 (3.346)	1.00 (2.21)	
1SP A3.2	3.2 (0.20)	200 (2900)	230 (3335)	250 (3625)	4500	14.4 (3.80)	400	1.21 (0.32)	82.6 (3.252)	39.3 (1.547)	70.6 (2.780)	85 (3.346)	1.04 (2.29)	
1SP A3.7	3.7 (0.23)	200 (2900)	230 (3335)	250 (3625)	4000	14.8 (3.91)	400	1.40 (0.37)	84.6 (3.331)	40.3 (1.587)	72.6 (2.858)	90 (3.543)	1.07 (2.36)	
1SP A4.2	4.2 (0.26)	180 (2610)	210 (3045)	230 (3335)	3500	14.7 (3.88)	400	1.60 (0.42)	86.5 (3.406)	41.25 (1.624)	74.5 (2.933)	90 (3.543)	1.10 (2.43)	
1SP A5.0	5.0 (0.31)	180 (2610)	210 (3045)	230 (3335)	3000	15 (3.96)	400	1.90 (0.50)	89.6 (3.528)	42.8 (1.685)	77.6 (3.055)	95 (3.740)	1.14 (2.51)	
1SP A6.3	6.3 (0.38)	170 (2465)	190 (2755)	210 (3045)	2700	17 (4.49)	400	2.39 (0.63)	94.7 (3.728)	45.35 (1.785)	82.7 (3.256)	100 (3.937)	1.22 (2.69)	
1SP A7.8	7.76 (0.47)	170 (2465)	190 (2755)	210 (3045)	2500	19.4 (5.13)	400	2.95 (0.78)	100.4 (3.953)	48.2 (1.898)	88.4 (3.480)	105 (4.134)	1.30 (2.87)	
1SP A9.8	9.78 (0.60)	150 (2175)	170 (2465)	190 (2755)	2000	19.6 (5.18)	400	3.71 (0.98)	108.3 (4.264)	52.15 (2.053)	96.3 (3.791)	115 (4.528)	1.41 (3.11)	

* Value collected during the testing at 1500 rpm

Example of ordering code

1SP	A	3.7	D	E32 BX	-	17	GG	0	(VT)
-----	---	-----	---	--------	---	----	----	---	------

1SP	Pump type	see table
A	Flange and cover material	A = Aluminium
3.7	Displacement	see table
D	Clockwise rotation	D = Clockwise rotation S = Anticlockwise rotation
E 32 BX	Flange type	E 32 BX
—		
17	Shaft type	17 - M32
GG	Connections type	GG - NN - TT - UU - NG - TG - UG
0	Connections positions	0 - 1 - 3 - 4
(VT)	Optional	(VT) Viton seals (optional) VLP-I (N) Pressure relief valve (page A-27)

Conn Port Connections

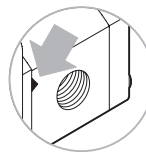
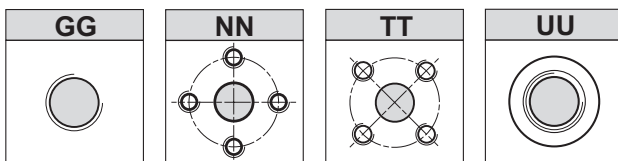

The sign on the body identifies the **suction side** for the pumps.

Port Connection positions

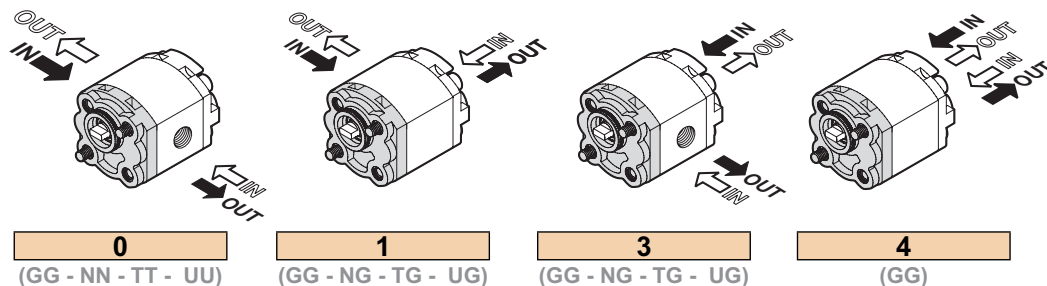

Rotation	
D	S

SEE PAGE 285 FOR PRICES

(Power-pack fixing)

Dimensions

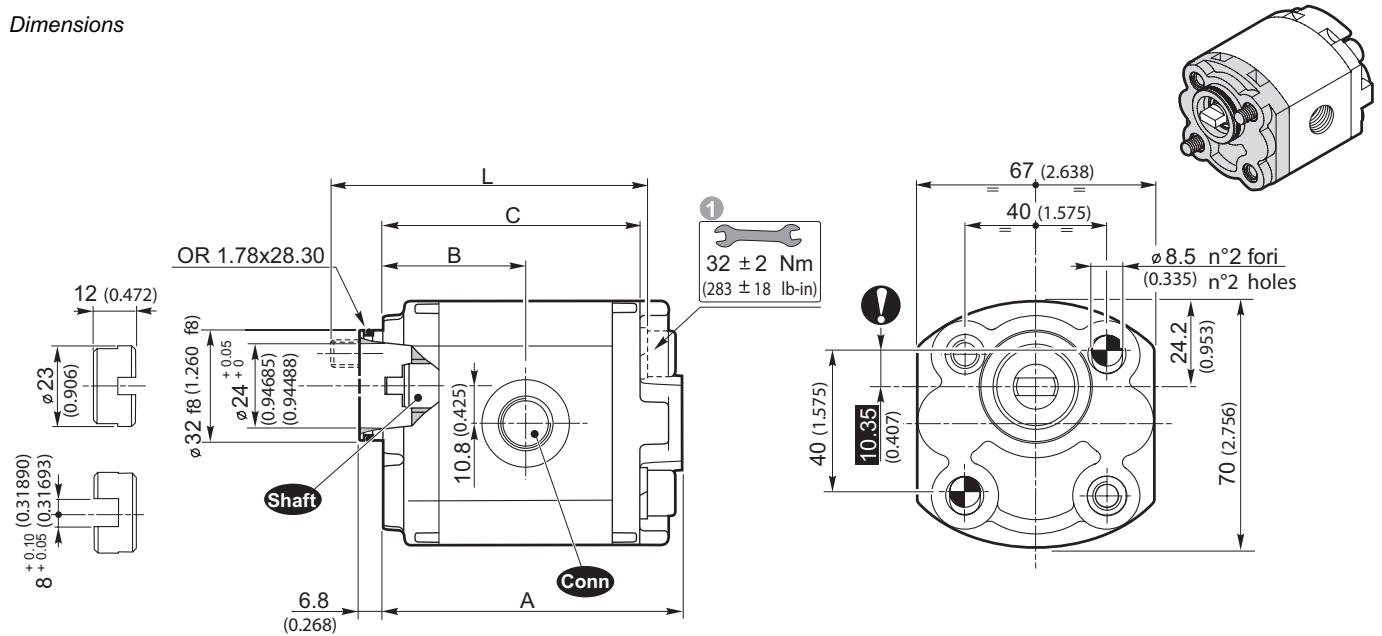

Shaft Available shafts

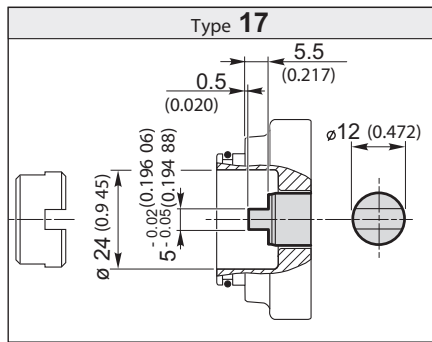

Torque 12 Nm / 8.9 ft-lbs

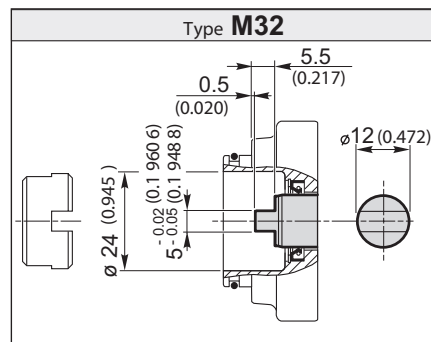

Torque 12 Nm / 8.9 ft-lbs

SEE PAGE 247 FOR PORT SIZES AVAILABLE

1 Tightening torque of screws: 283 \pm 18 lb-in. Use screws type 10.9 - 12.9 UNI EN 20898/1. The screws kit for the pump assembling should be ordered separately. Ordering code of assembling Kit:

0019W + Length L (see table)

The assembling of the pump should be effected with 2 screw studs type 10.9 - 12.9 pre-tighten at 221 \pm 18 lb-in. Fix the pump by self-locking nuts with tightening torque 283 \pm 18 lb-in.

SEE PAGE 285 FOR PRICES

Technical data

Size	Displacement [cm ³ /rev] (in ³ /rev)	Max. working pressure			Max. speed [g/min] (rpm)	Max. flow [lt/min] (Gal/min)	Min. speed [g/min] (rpm)	Min. flow [lt/min] (Gal/min)	Dimensions				Mass [Kg] (lbs)	Min. volumetric efficiency %
		P1	P2	P3					A	B	C	L ①		
		[bar] (PSI)	[bar] (PSI)	[bar] (PSI)					[mm] (inch)	[mm] (inch)	[mm] (inch)	[mm] (inch)		
1SP A0.9	0.89 (0.05)	210 (3045)	240 (3480)	260 (3770)	6000	5.3 (1.40)	600	0.49 (0.13)	73.6 (2.898)	34.8 (1.370)	61.6 (2.425)	80 (3.150)	0.91 (2.01)	92*
1SP A1.2	1.18 (0.07)	210 (3045)	240 (3480)	260 (3770)	6000	7.1 (1.88)	600	0.65 (0.17)	74.7 (2.941)	35.35 (1.392)	62.7 (2.469)	80 (3.150)	0.93 (2.05)	
1SP A1.6	1.6 (0.10)	210 (3045)	240 (3480)	260 (3770)	6000	9.6 (2.54)	400	0.61 (0.16)	76.4 (3.008)	36.2 (1.425)	64.4 (2.535)	80 (3.150)	0.95 (2.09)	
1SP A2.0	2.0 (0.12)	210 (3045)	240 (3480)	260 (3770)	5500	11 (2.91)	400	0.76 (0.20)	77.9 (3.067)	36.95 (1.455)	65.9 (2.594)	80 (3.150)	0.97 (2.14)	95*
1SP A2.5	2.5 (0.15)	210 (3045)	240 (3480)	260 (3770)	5000	12.5 (3.30)	400	0.95 (0.25)	79.9 (3.146)	37.95 (1.494)	67.9 (2.673)	85 (3.346)	1.00 (2.21)	
1SP A3.2	3.2 (0.20)	200 (2900)	230 (3335)	250 (3625)	4500	14.4 (3.80)	400	1.21 (0.32)	82.6 (3.252)	39.3 (1.547)	70.6 (2.780)	85 (3.346)	1.04 (2.29)	
1SP A3.7	3.7 (0.23)	200 (2900)	230 (3335)	250 (3625)	4000	14.8 (3.91)	400	1.40 (0.37)	84.6 (3.331)	40.3 (1.587)	72.6 (2.858)	90 (3.543)	1.07 (2.36)	95*
1SP A4.2	4.2 (0.26)	180 (2610)	210 (3045)	230 (3335)	3500	14.7 (3.88)	400	1.60 (0.42)	86.5 (3.406)	41.25 (1.624)	74.5 (2.933)	90 (3.543)	1.10 (2.43)	
1SP A5.0	5.0 (0.31)	180 (2610)	210 (3045)	230 (3335)	3000	15 (3.96)	400	1.90 (0.50)	89.6 (3.528)	42.8 (1.685)	77.6 (3.055)	95 (3.740)	1.14 (2.51)	
1SP A6.3	6.3 (0.38)	170 (2465)	190 (2755)	210 (3045)	2700	17 (4.49)	400	2.39 (0.63)	94.7 (3.728)	45.35 (1.785)	82.7 (3.256)	100 (3.937)	1.22 (2.69)	95*
1SP A7.8	7.76 (0.47)	170 (2465)	190 (2755)	210 (3045)	2500	19.4 (5.13)	400	2.95 (0.78)	100.4 (3.953)	48.2 (1.898)	88.4 (3.480)	105 (4.134)	1.30 (2.87)	
1SP A9.8	9.78 (0.60)	150 (2175)	170 (2465)	190 (2755)	2000	19.6 (5.18)	400	3.71 (0.98)	108.3 (4.264)	52.15 (2.053)	96.3 (3.791)	115 (4.528)	1.41 (3.11)	

* Value collected during the testing at 1500 rpm

Example of ordering code

1SP	A	3.7	D	E32 CX	-	17	GG	0	(VT)
-----	---	-----	---	--------	---	----	----	---	------

1SP	Pump type	see table
A	Flange and cover material	A = Aluminium
3.7	Displacement	see table
D	Clockwise rotation	D = Clockwise rotation S = Anticlockwise rotation
E 32 CX	Flange type	E 32 CX
—		
17	Shaft type	17 - M32
GG	Connections type	GG - NN - TT - UU - NG - TG - UG
0	Connections positions	0 - 1 - 3 - 4
(VT)	Optional	(VT) Viton seals (optional) VLP-I (N) Pressure relief valve (page A-27)

Conn Port Connections

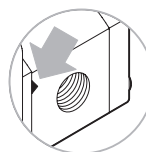
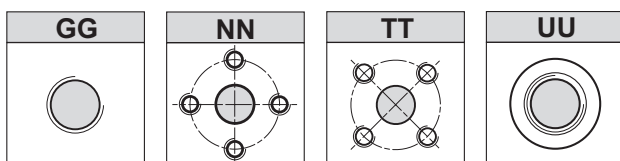

The sign on the body identifies the **suction side** for the pumps.

Port Connection positions

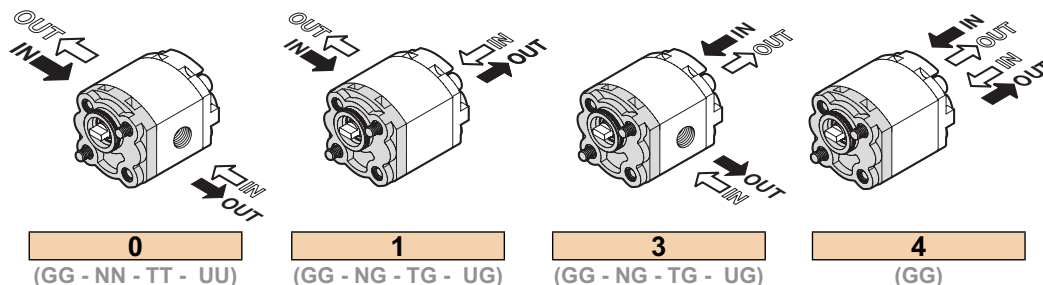

Rotation	
D	S

SEE PAGE 285 FOR PRICES

Dimensions

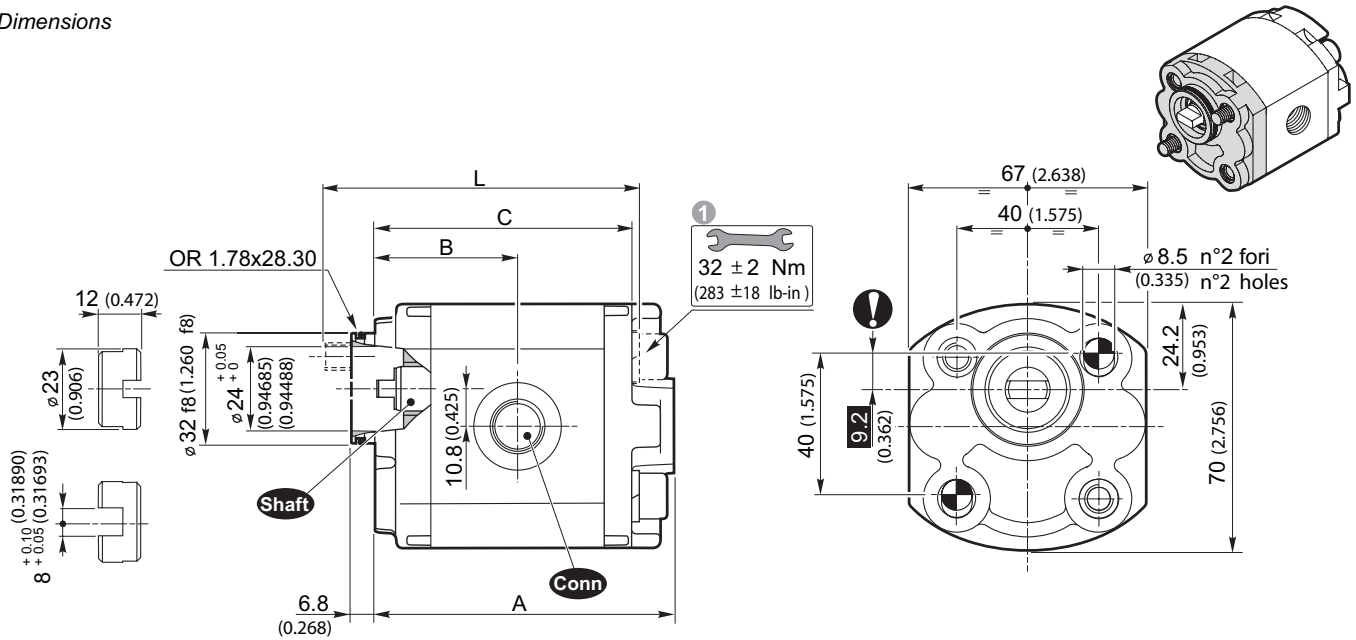

Shaft Available shafts

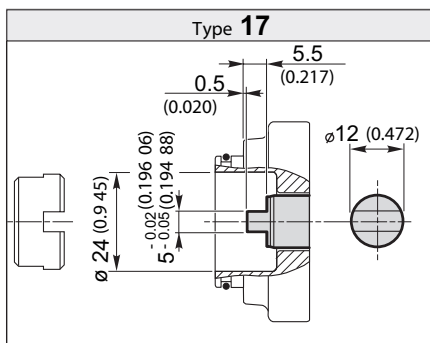

Torque 12 Nm / 8.9 ft-lbs

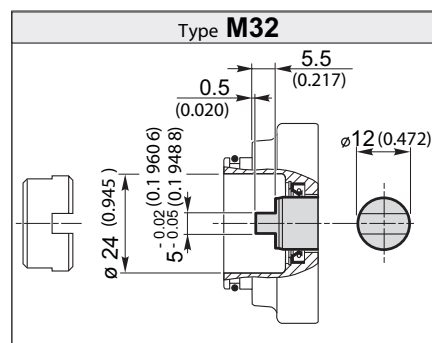

Torque 12 Nm / 8.9 ft-lbs

SEE PAGE 247 FOR PORT SIZES AVAILABLE

①

Tightening torque of screws: 283 \pm 18 lb-in. Use screws type 10.9 - 12.9 UNI EN 20898/1.

The screws kit for the pump assembling should be ordered separately. Ordering code of assembling Kit:

0019W + Length L (see table)

The assembling of the pump should be effected with 2 screw studs type 10.9 - 12.9 pre-tighten at 221 \pm 18 lb-in.

Fix the pump by self-locking nuts with tightening torque 283 \pm 18 lb-in.

SEE PAGE 285 FOR PRICES

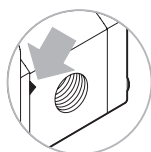
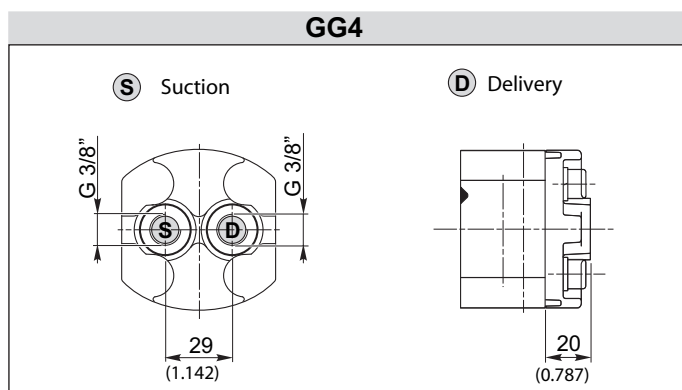
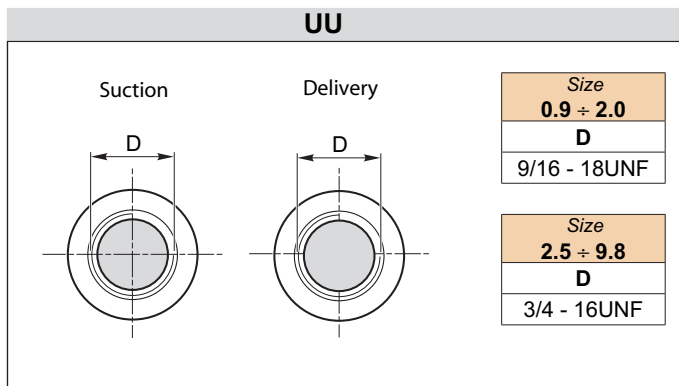
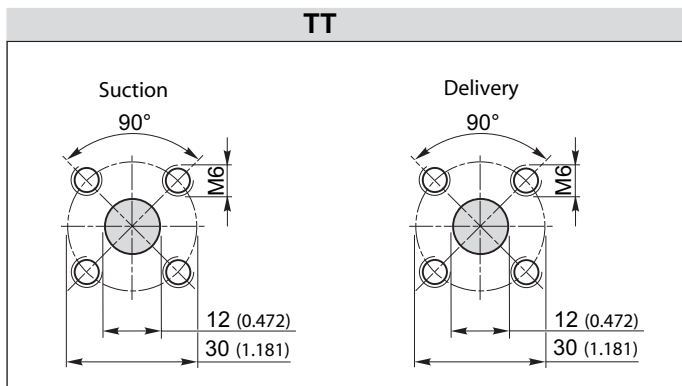
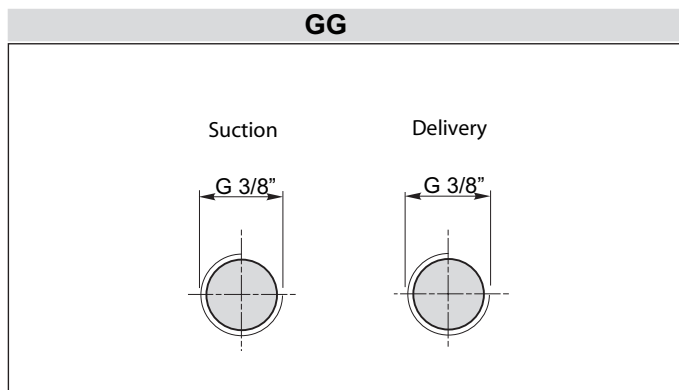
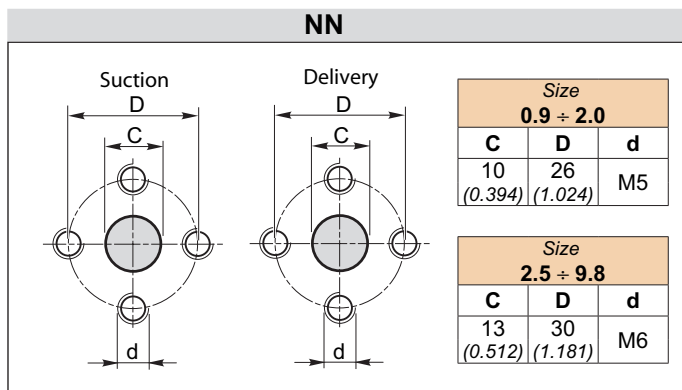

The sign on the body identifies the **suction side** for the pumps.

Port Connection positions

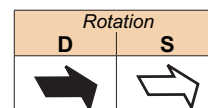
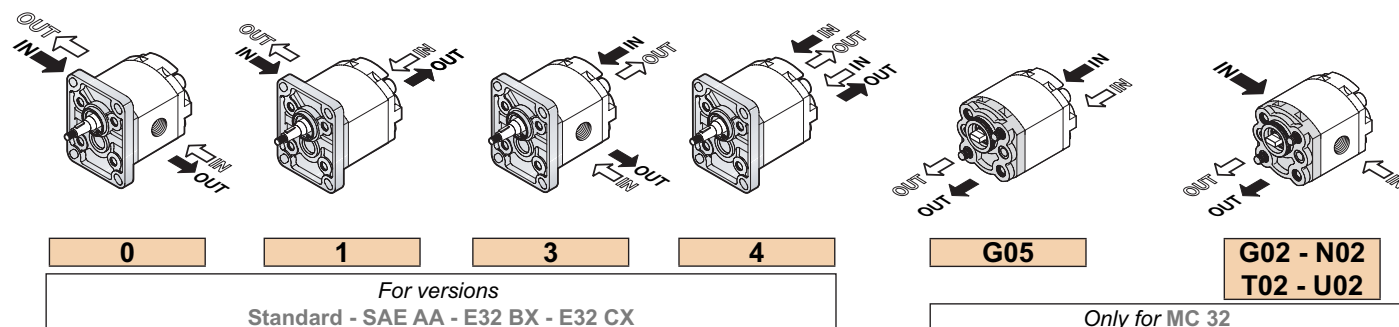

SEE PAGE 285 FOR PRICES

VLP- I (N)

Pressure relief valve

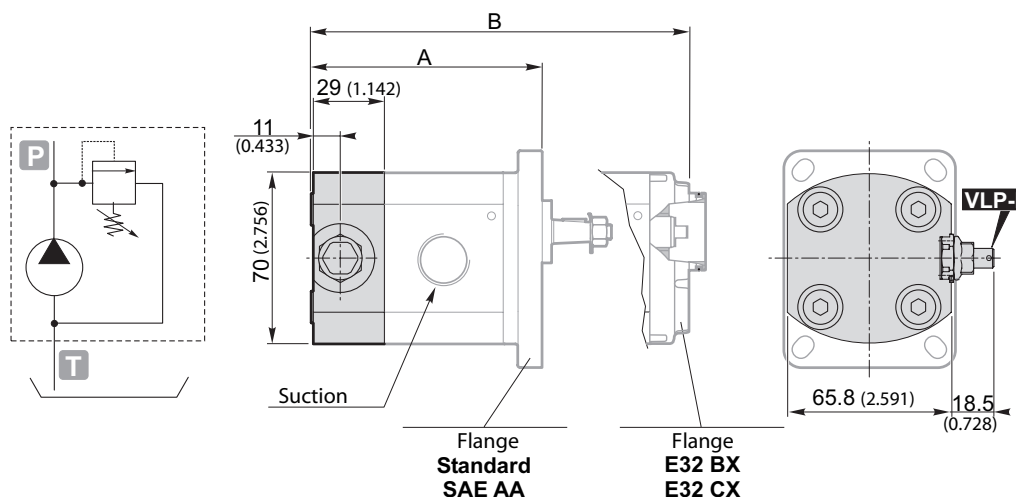
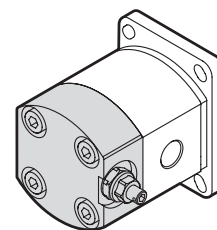

	A		B
	Standard	SAE AA	E32 BX E32 CX
1SP A0.9	82.6 (3.252)	86.1 (3.390)	82.6 (3.252)
1SP A1.2	83.7 (3.295)	87.2 (3.433)	83.7 (3.295)
1SP A1.6	85.4 (3.362)	88.9 (3.500)	85.4 (3.362)
1SP A2.0	86.9 (3.421)	90.4 (3.559)	86.9 (3.421)
1SP A2.5	88.9 (3.500)	92.4 (3.638)	88.9 (3.500)
1SP A3.2	91.6 (3.606)	95.1 (3.744)	91.6 (3.606)
1SP A3.7	93.6 (3.685)	97.1 (3.823)	93.6 (3.685)
1SP A4.2	95.5 (3.760)	99.0 (3.898)	95.5 (3.760)
1SP A5.0	98.6 (3.882)	102.1 (4.020)	98.6 (3.882)
1SP A6.3	103.7 (4.083)	107.2 (4.220)	103.7 (4.083)
1SP A7.8	109.4 (4.307)	112.9 (4.445)	109.4 (4.307)
1SP A9.8	117.3 (4.618)	120.8 (4.756)	117.3 (4.618)

Warning.

The pressure relief valve can be applied by substituting the rear cover (only internal relief is set).

The opening of the pressure relief valve should be carry out for times not over 10" each minute to avoid the overheating of the pump.

Esempio di ordinazione in codice / Example of ordering code

1SP	A	2.5	D	SAE AA	-	10	GG0	VLP-I	(N)
-----	---	-----	---	--------	---	----	-----	-------	-----

VLP-I	Cover with VPL at internal exhaust	VPL-I
(N)	Spring type	B - N - G - R (See table)

		Spring type			
		B	N	G	R
		white spring	black spring	yellow spring	red spring
Calibration fields*	[bar] (psi)	30 ÷ 80 (435 ÷ 1160)	81 ÷ 200 (1175 ÷ 2900)	201 ÷ 300 (2915 ÷ 4350)	301 ÷ 400 (4365 ÷ 5800)

* Without setting request, it will be considered standard (black spring: 1740 psi).

Flange and cover in Aluminium

Technical data

Size	Displacement [cm ³ /rev] (in ³ /rev)	Max. working pressure			Max. speed [g/min] (rpm)	Max. flow [l/min] (Gal/min)	Min. speed [g/min] (rpm)	Min. flow [l/min] (Gal/min)	Dimensions		Mass [Kg] (lbs)	Min. volumetric efficiency %
		P1 [bar] (PSI)	P2 [bar] (PSI)	P3 [bar] (PSI)					A [mm] (inch)	B [mm] (inch)		
2SP A4	4 (0.24)	250 (3625)	270 (3915)	290 (4205)	4000	16 (4.23)	500	1.9 (0.50)	44.4 (1.748)	93 (3.661)	2.30 (5.07)	95*
2SP A6	6 (0.37)	250 (3625)	270 (3915)	290 (4205)	4000	24 (6.34)	500	2.85 (0.75)	46 (1.811)	96.3 (3.791)	2.45 (5.40)	
2SP A8	8.5 (0.52)	250 (3625)	270 (3915)	290 (4205)	3500	29.7 (7.85)	500	4.03 (1.06)	48.1 (1.894)	100.5 (3.957)	2.60 (5.73)	
2SP A11	11 (0.67)	250 (3625)	270 (3915)	290 (4205)	3500	38.5 (10.17)	500	5.22 (1.38)	50.2 (1.976)	104.6 (4.118)	2.70 (5.95)	
2SP A14	14 (0.85)	250 (3625)	270 (3915)	290 (4205)	3500	49 (12.95)	500	6.65 (1.76)	52.7 (2.075)	109.6 (4.315)	2.80 (6.17)	
2SP A16	16.5 (1.01)	230 (3335)	240 (3480)	250 (3625)	3500	57.7 (15.24)	500	7.83 (2.07)	54.8 (2.157)	113.8 (4.480)	2.95 (6.51)	
2SP A19	19.5 (1.19)	210 (3045)	220 (3190)	230 (3335)	3300	64.3 (16.99)	500	9.26 (2.45)	57.3 (2.256)	118.8 (4.677)	3.10 (6.84)	
2SP A22	22.5 (1.37)	190 (2755)	200 (2900)	210 (3045)	2800	63 (16.64)	500	10.68 (2.82)	59.8 (2.354)	123.8 (4.874)	3.25 (7.17)	
2SP A26	26 (1.59)	170 (2465)	180 (2610)	190 (2755)	2500	65 (17.17)	500	12.35 (3.26)	62.7 (2.469)	129.6 (5.102)	3.40 (7.50)	

* Value collected during the testing at 1500 rpm)

Example of ordering code

2SP	A	14	D	(H)	-	10	G	(VT)
-----	---	----	---	-----	---	----	---	------



2SP	Pump type	see table
A	Flange and cover	A = Aluminium
14	Displacement	see table
D	Clockwise rotation	D = Clockwise rotation S = Anticlockwise rotation
— ⁽¹⁾	Flange type	
(H)	Stiffening seal for low suction pressure	(optional)
—		
10	Shaft type	10 - 11 - 12 - 13 - 14 - 15 - 16
G	Connections type	G - N - T - M - U - W - F
(VT)	Optional	(VT) Viton seals (optional) VLP-I (N) - VLP-E (N) Pressure relief valve (page A-49)

⁽¹⁾ It is not necessary to indicate STANDARD flange

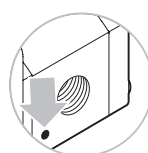
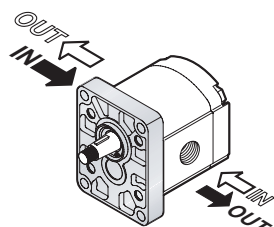
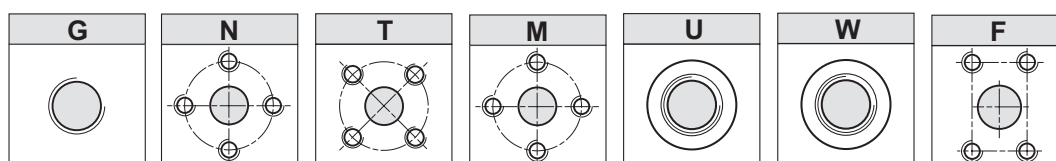
Conn Port Connections



The sign on the body identifies the **suction side** for the pumps.

Rotation	
D	S
	

SEE PAGE 285 FOR PRICES

Flange and cover in Aluminium

Dimensions

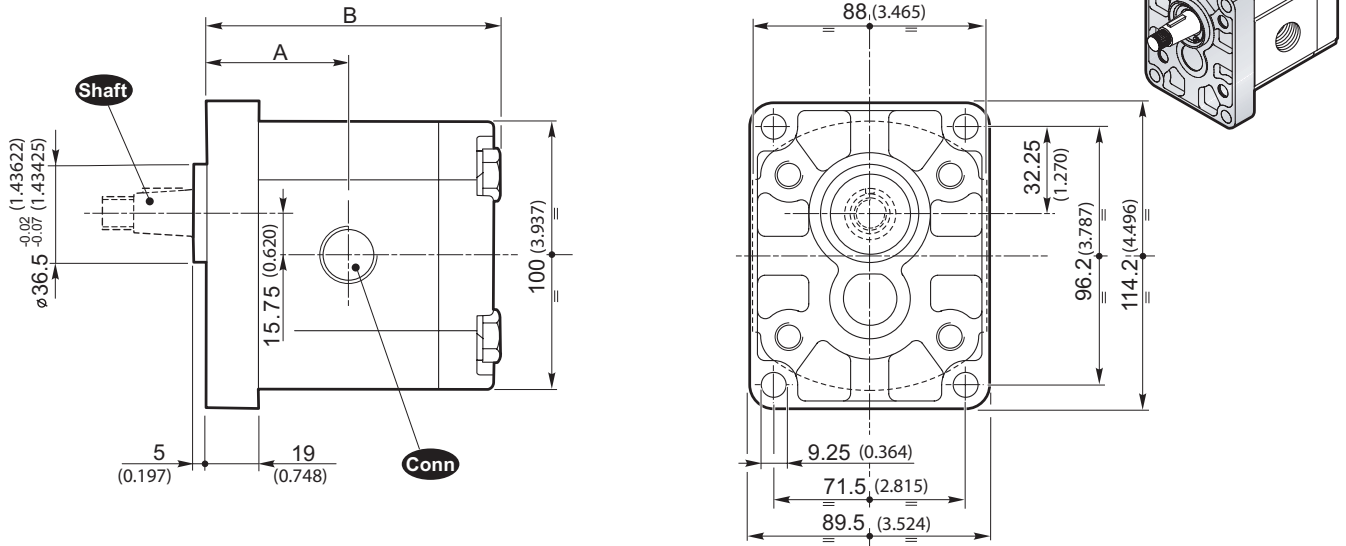

Shaft Available shafts

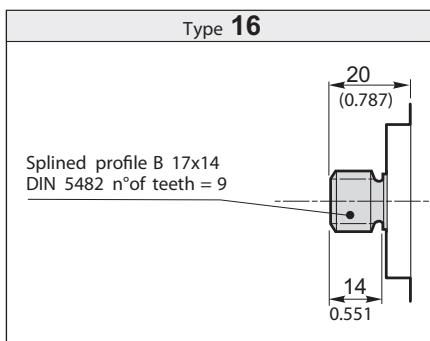
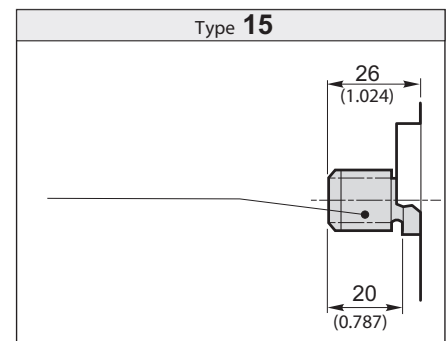
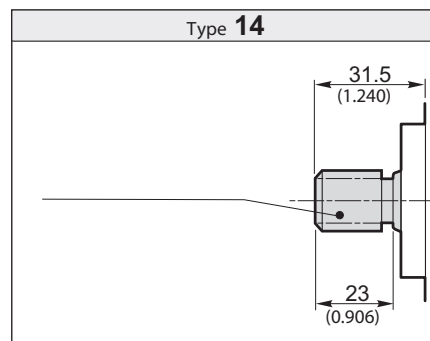
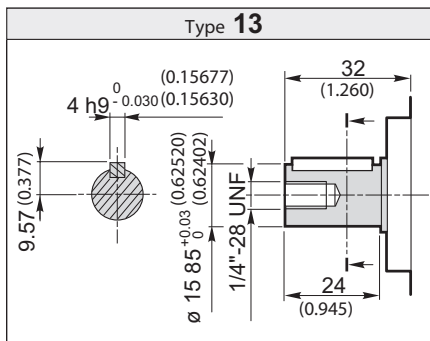
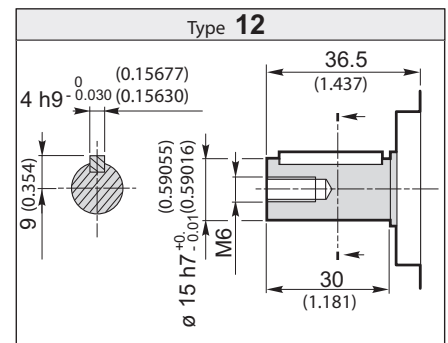
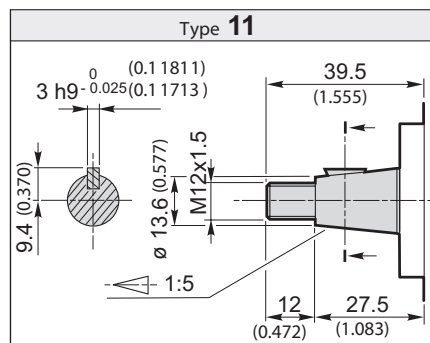
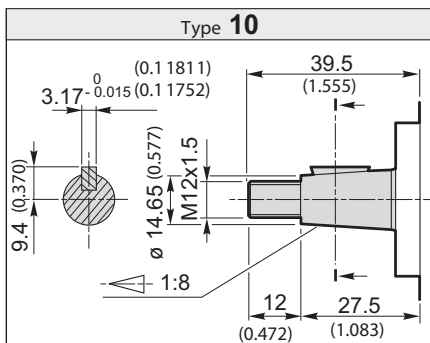

SEE PAGE 269 FOR PORT SIZES AVAILABLE

SEE PAGE 285 FOR PRICES

Flange and cover in Cast iron

Technical data

Size	Displacement [cm ³ /rev] (in ³ /rev)	Max. working pressure			Max. speed [g/min] (rpm)	Max. flow [l/min] (Gal/min)	Min. speed [g/min] (rpm)	Min. flow [l/min] (Gal/min)	Dimensions		Mass [Kg] (lbs)	Min. volumetric efficiency %
		P1 [bar] (PSI)	P2 [bar] (PSI)	P3 [bar] (PSI)					A [mm] (inch)	B [mm] (inch)		
2SP G4	4 (0.24)	280 (4060)	300 (4350)	320 (4640)	4000	16 (4.23)	500	1.9 (0.50)	44.4 (1.748)	93 (3.661)	3.40 (7.50)	95*
2SP G6	6 (0.37)	280 (4060)	300 (4350)	320 (4640)	4000	24 (6.34)	500	2.85 (0.75)	46 (1.811)	96.3 (3.791)	3.55 (7.83)	
2SP G8	8.5 (0.52)	280 (4060)	300 (4350)	320 (4640)	3500	29.7 (7.85)	500	4.03 (1.06)	48.1 (1.894)	100.5 (3.957)	3.70 (8.16)	
2SP G11	11 (0.67)	280 (4060)	300 (4350)	320 (4640)	3500	38.5 (10.17)	500	5.22 (1.38)	50.2 (1.976)	104.6 (4.118)	3.80 (8.38)	
2SP G14	14 (0.85)	270 (3915)	280 (4060)	290 (4205)	3500	49 (12.95)	500	6.65 (1.76)	52.7 (2.075)	109.6 (4.315)	3.90 (8.60)	
2SP G16	16.5 (1.01)	230 (3335)	240 (3480)	250 (3625)	3500	57.7 (15.24)	500	7.83 (2.07)	54.8 (2.157)	113.8 (4.480)	4.05 (8.93)	
2SP G19	19.5 (1.19)	210 (3045)	220 (3190)	230 (3335)	3300	64.3 (16.99)	500	9.26 (2.45)	57.3 (2.256)	118.8 (4.677)	4.20 (9.26)	
2SP G22	22.5 (1.37)	190 (2755)	200 (2900)	210 (3045)	2800	63 (16.64)	500	10.68 (2.82)	59.8 (2.354)	123.8 (4.874)	4.35 (9.59)	
2SP G26	26 (1.59)	170 (2465)	180 (2610)	190 (2755)	2500	65 (17.17)	500	12.35 (3.26)	62.7 (2.469)	129.6 (5.102)	4.50 (9.92)	

* Value collected during the testing at 1500 rpm

Example of ordering code

2SP	G	14	D	(H)	-	10	G	(VT)
------------	----------	-----------	----------	------------	----------	-----------	----------	-------------



2SP	Pump type	see table
G	Flange and cover	G = Cast iron
14	Displacement	see table
D	Clockwise rotation	D = Clockwise rotation S = Anticlockwise rotation
— ⁽¹⁾	Flange type	
(H)	Stiffening seal for low suction pressure	(optional)
—		
10	Shaft type	10 - 11 - 12 - 13 - 14 - 15 - 16
G	Connections type	G - N - T - M - U - W - F
(VT)	Optional	(VT) Viton seals (optional) VLP-I (N) - VLP-E (N) Pressure relief valve (page A-49)

⁽¹⁾ It is not necessary to indicate STANDARD flange

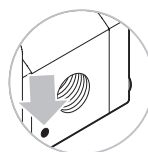
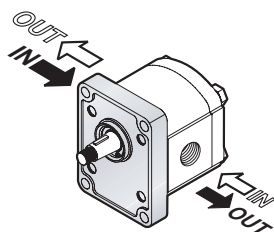
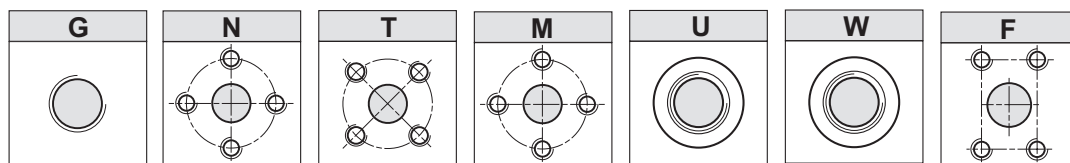
Conn Port Connections



The sign on the body identifies the **suction side** for the pumps.

Rotation	
D	S
	

SEE PAGE 285 FOR PRICES

Flange and cover in Cast iron

Dimensions

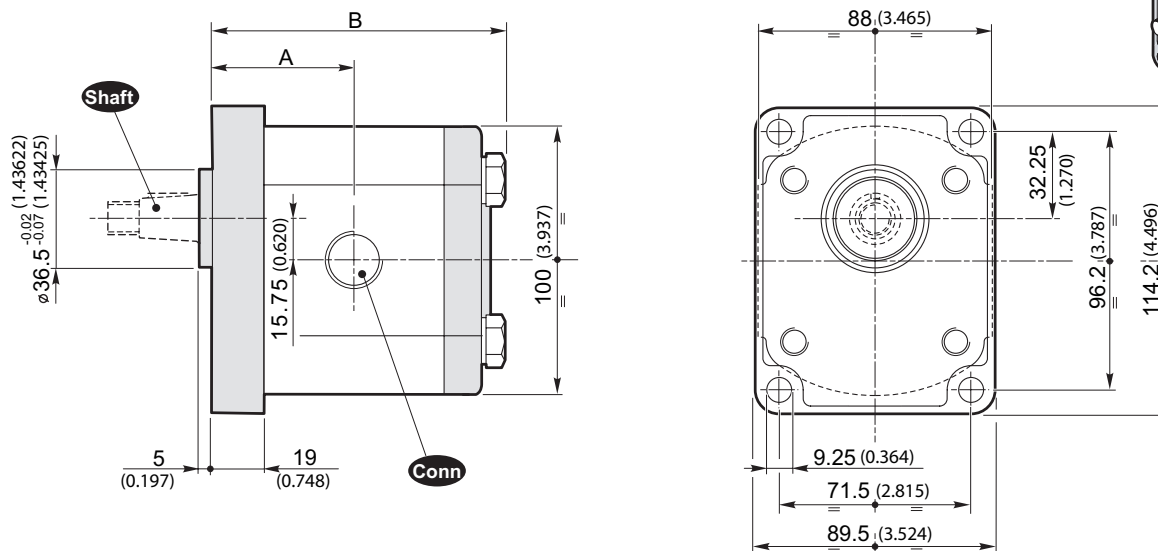

Shaft Available shafts

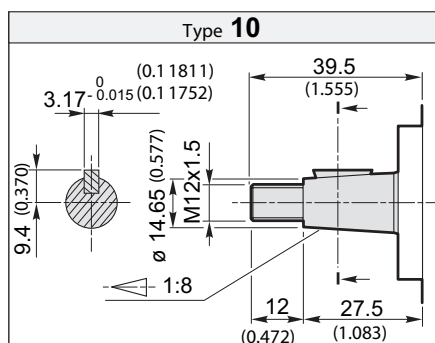

Torque 98 Nm / 72.3 ft-lbs

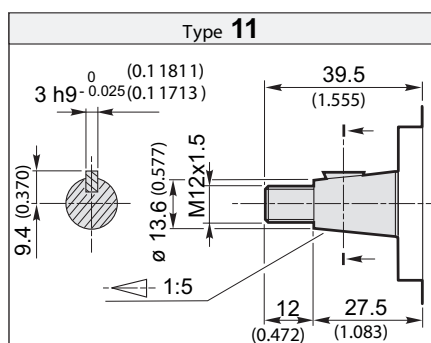

Torque 98 Nm / 72.3 ft-lbs

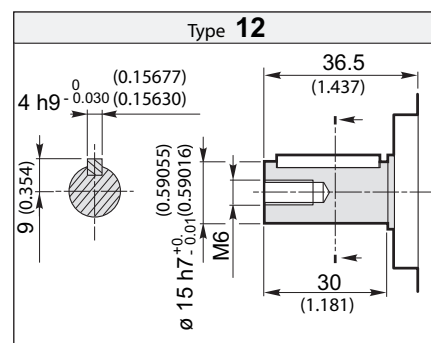

Torque 98 Nm / 72.3 ft-lbs

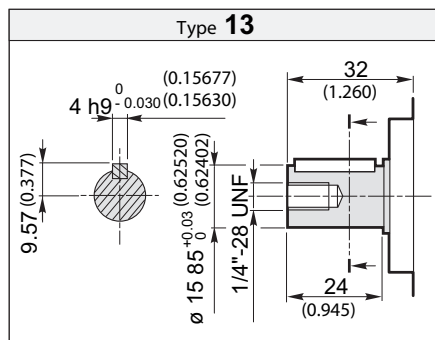

Torque 98 Nm / 72.3 ft-lbs

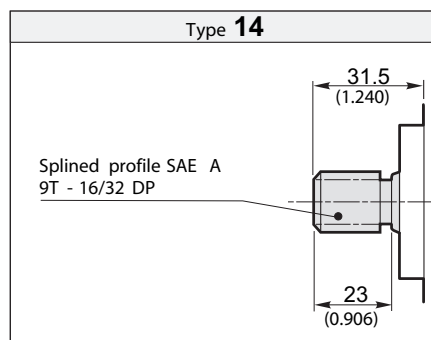

Torque 98 Nm / 72.3 ft-lbs

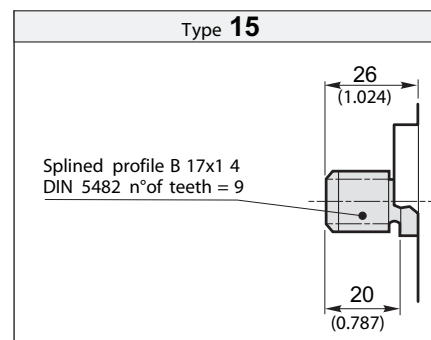

Torque 98 Nm / 72.3 ft-lbs

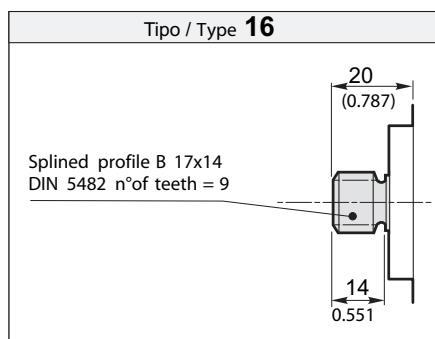

Torque 98 Nm / 72.3 ft-lbs

SEE PAGE 269 FOR PORT SIZES AVAILABLE

SEE PAGE 285 FOR PRICES

Flange and cover in Aluminium

Technical data

Size	Displacement [cm ³ /rev] (in ³ /rev)	Max. working pressure			Max. speed [g/min] (rpm)	Max. flow [l/min] (Gal/min)	Min. speed [g/min] (rpm)	Min. flow [l/min] (Gal/min)	Dimensions		Mass [Kg] (lbs)	Min. volumetric efficiency %
		P1 [bar] (PSI)	P2 [bar] (PSI)	P3 [bar] (PSI)					A [mm] (inch)	B [mm] (inch)		
2SP A4	4 (0.24)	250 (3625)	270 (3915)	290 (4205)	4000	16 (4.23)	500	1.9 (0.50)	44.4 (1.748)	93 (3.661)	2.30 (5.07)	95*
2SP A6	6 (0.37)	250 (3625)	270 (3915)	290 (4205)	4000	24 (6.34)	500	2.85 (0.75)	46 (1.811)	96.3 (3.791)	2.45 (5.40)	
2SP A8	8.5 (0.52)	250 (3625)	270 (3915)	290 (4205)	3500	29.7 (7.85)	500	4.03 (1.06)	48.1 (1.894)	100.5 (3.957)	2.60 (5.73)	
2SP A11	11 (0.67)	250 (3625)	270 (3915)	290 (4205)	3500	38.5 (10.17)	500	5.22 (1.38)	50.2 (1.976)	104.6 (4.118)	2.70 (5.95)	
2SP A14	14 (0.85)	250 (3625)	270 (3915)	290 (4205)	3500	49 (12.95)	500	6.65 (1.76)	52.7 (2.075)	109.6 (4.315)	2.80 (6.17)	
2SP A16	16.5 (1.01)	230 (3335)	240 (3480)	250 (3625)	3500	57.7 (15.24)	500	7.83 (2.07)	54.8 (2.157)	113.8 (4.480)	2.95 (6.51)	
2SP A19	19.5 (1.19)	210 (3045)	220 (3190)	230 (3335)	3300	64.3 (16.99)	500	9.26 (2.45)	57.3 (2.256)	118.8 (4.677)	3.10 (6.84)	
2SP A22	22.5 (1.37)	190 (2755)	200 (2900)	210 (3045)	2800	63 (16.64)	500	10.68 (2.82)	59.8 (2.354)	123.8 (4.874)	3.25 (7.17)	
2SP A26	26 (1.59)	170 (2465)	180 (2610)	190 (2755)	2500	65 (17.17)	500	12.35 (3.26)	62.7 (2.469)	129.6 (5.102)	3.40 (7.50)	

* Value collected during the testing at 1500 rpm

Example of ordering code

2SP | A | 14 | D | SAE A | (H) | - | 10 | G | (VT)

2SP	Pump type	see table
A	Flange and cover	A = Aluminium
14	Displacement	see table
D	Clockwise rotation	D = Clockwise rotation S = Anticlockwise rotation
SAE A	Flange type	SAE A - SAE A-OR
(H)	Stiffening seal for low suction pressure	(optional)
—		
10	Shaft type	10 - 11 - 12 - 13 - 14 - 15 - 16
G	Connections type	G - N - T - M - U - W - F
(VT)	Optional	(VT) Viton seals (optional) VLP-I (N) - VLP-E (N) Pressure relief valve (page A-49)

Conn Port Connections

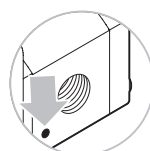
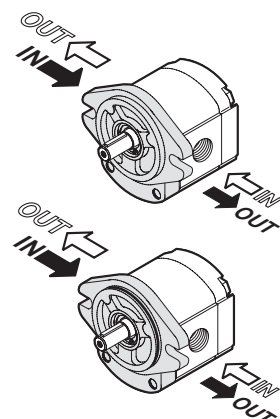
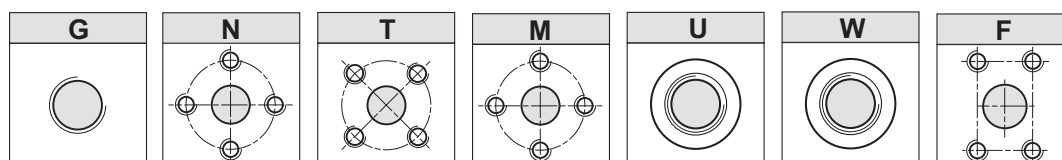

The sign on the body identifies the **suction side** for the pumps.

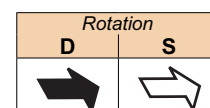

SEE PAGE 285 FOR PRICES

Flange and cover in Aluminium

Dimensions

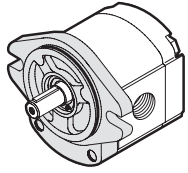

SAE A-OR

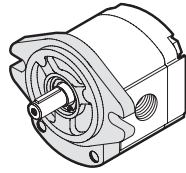

SAE A

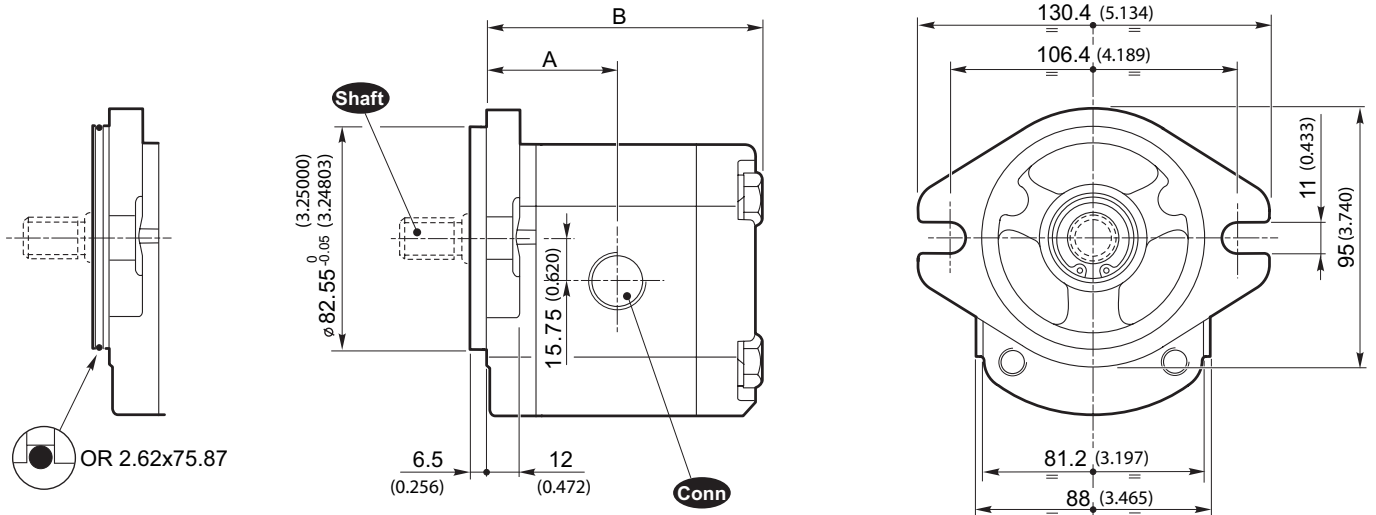

Shaft Available shafts

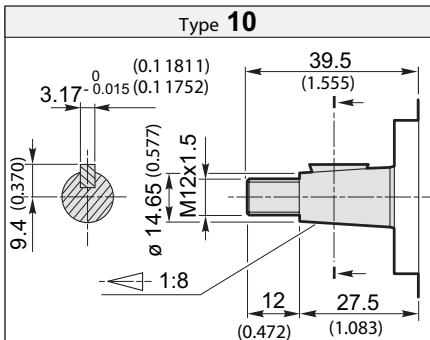

Torque 98 Nm / 72.3 ft-lbs

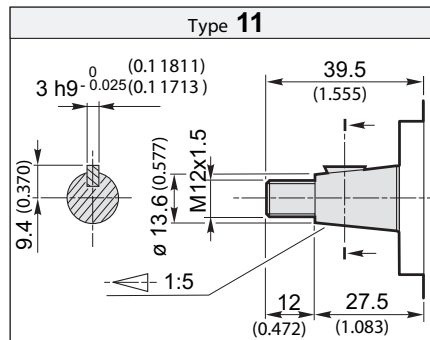

Torque 98 Nm / 72.3 ft-lbs

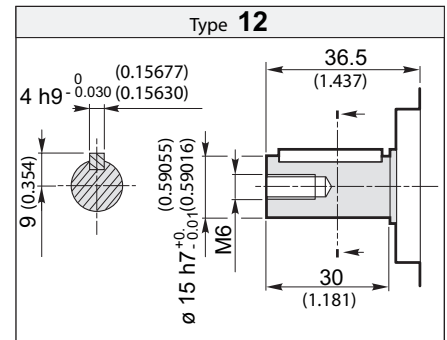

Torque 98 Nm / 72.3 ft-lbs

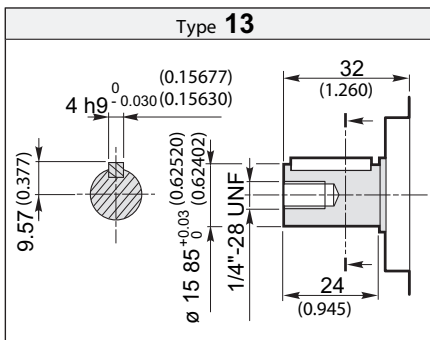

Torque 98 Nm / 72.3 ft-lbs

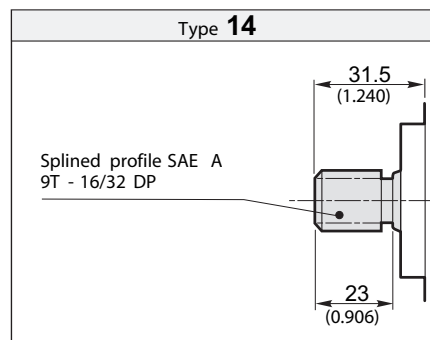

Torque 98 Nm / 72.3 ft-lbs

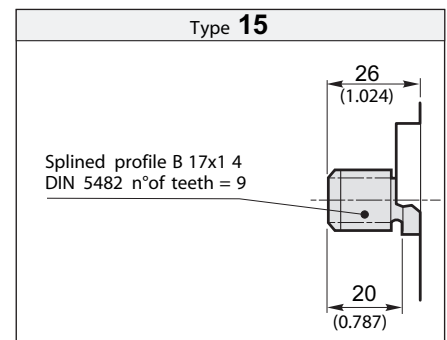

Torque 98 Nm / 72.3 ft-lbs

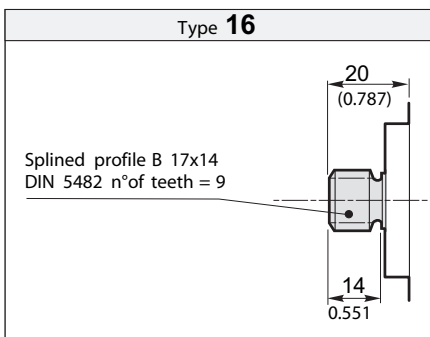

Torque 98 Nm / 72.3 ft-lbs

SEE PAGE 269 FOR PORT SIZES AVAILABLE

SEE PAGE 285 FOR PRICES

Flange and cover in Cast iron

Technical data

Size	Displacement [cm ³ /rev] (in ³ /rev)	Max. working pressure			Max. speed [g/min] (rpm)	Max. flow [l/min] (Gal/min)	Min. speed [g/min] (rpm)	Min. flow [l/min] (Gal/min)	Dimensions		Mass [Kg] (lbs)	Min. volumetric efficiency %
		P1 [bar] (PSI)	P2 [bar] (PSI)	P3 [bar] (PSI)					A [mm] (inch)	B [mm] (inch)		
2SP G4	4 (0.24)	280 (4060)	300 (4350)	320 (4640)	4000	16 (4.23)	500	1.9 (0.50)	44.4 (1.748)	93 (3.661)	3.40 (7.50)	95*
2SP G6	6 (0.37)	280 (4060)	300 (4350)	320 (4640)	4000	24 (6.34)	500	2.85 (0.75)	46 (1.811)	96.3 (3.791)	3.55 (7.83)	
2SP G8	8.5 (0.52)	280 (4060)	300 (4350)	320 (4640)	3500	29.7 (7.85)	500	4.03 (1.06)	48.1 (1.894)	100.5 (3.957)	3.70 (8.16)	
2SP G11	11 (0.67)	280 (4060)	300 (4350)	320 (4640)	3500	38.5 (10.17)	500	5.22 (1.38)	50.2 (1.976)	104.6 (4.118)	3.80 (8.38)	
2SP G14	14 (0.85)	270 (3915)	280 (4060)	290 (4205)	3500	49 (12.95)	500	6.65 (1.76)	52.7 (2.075)	109.6 (4.315)	3.90 (8.60)	
2SP G16	16.5 (1.01)	230 (3335)	240 (3480)	250 (3625)	3500	57.7 (15.24)	500	7.83 (2.07)	54.8 (2.157)	113.8 (4.480)	4.05 (8.93)	
2SP G19	19.5 (1.19)	210 (3045)	220 (3190)	230 (3335)	3300	64.3 (16.99)	500	9.26 (2.45)	57.3 (2.256)	118.8 (4.677)	4.20 (9.26)	
2SP G22	22.5 (1.37)	190 (2755)	200 (2900)	210 (3045)	2800	63 (16.64)	500	10.68 (2.82)	59.8 (2.354)	123.8 (4.874)	4.35 (9.59)	
2SP G26	26 (1.59)	170 (2465)	180 (2610)	190 (2755)	2500	65 (17.17)	500	12.35 (3.26)	62.7 (2.469)	129.6 (5.102)	4.50 (9.92)	

* Value collected during the testing at 1500 rpm

Example of ordering code

2SP	G	14	D	SAE A	(H)	-	14	G	(VT)
------------	----------	-----------	----------	--------------	------------	----------	-----------	----------	-------------

2SP	Pump type	see table
G	Flange and cover	G = Cast iron
14	Displacement (see table)	see table
D	Clockwise rotation	D = Clockwise rotation S = Anticlockwise rotation
SAE A	Flange type	SAE A - SAE A-OR
(H)	Stiffening seal for low suction pressure (optional)	(optional)
-		
14	Shaft type	10 - 11 - 12 - 13 - 14 - 15 - 16
G	Connections type	G - N - T - M - U - W - F
(VT)	Optional	(VT) Viton seals (optional) VLP-I (N) - VLP-E (N) Pressure relief valve (page A-49)

Conn Port Connections

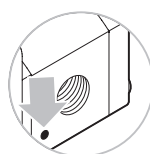
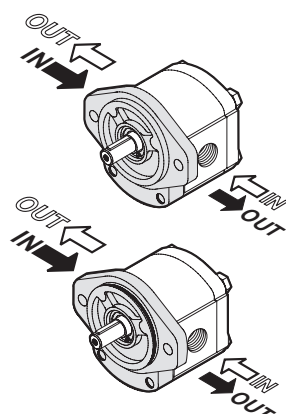
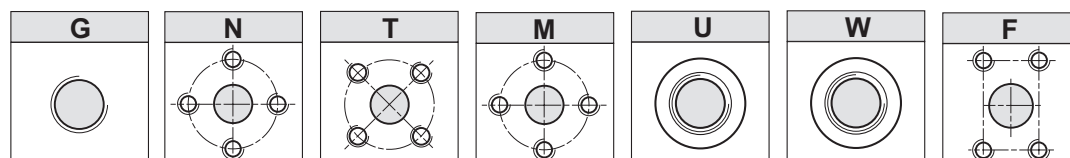

The sign on the body identifies the **suction side** for the pumps.

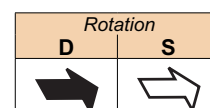

SEE PAGE 285 FOR PRICES

Flange and cover in Cast iron

Dimensions

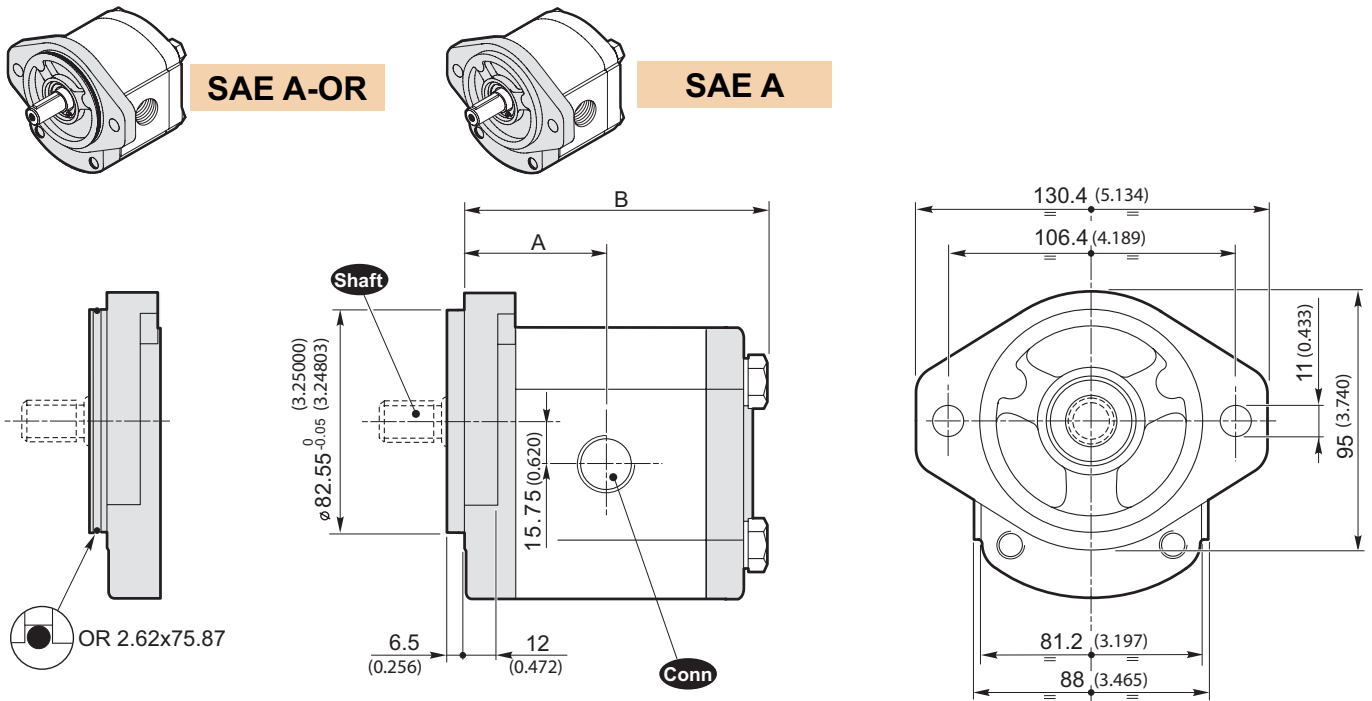

Shaft Available shafts

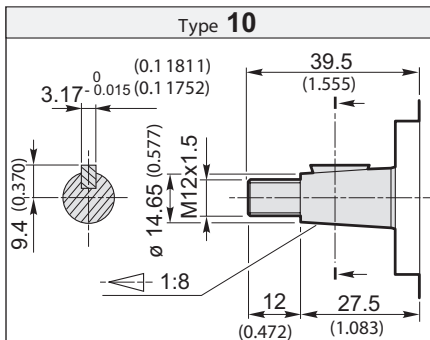

Torque 98 Nm / 72.3 ft-lbs

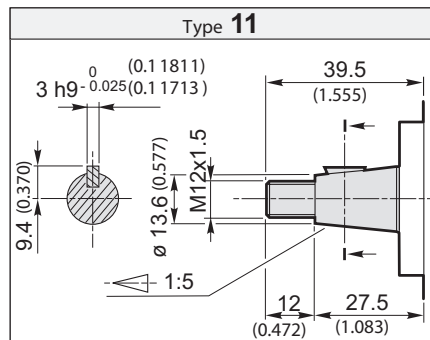

Torque 98 Nm / 72.3 ft-lbs

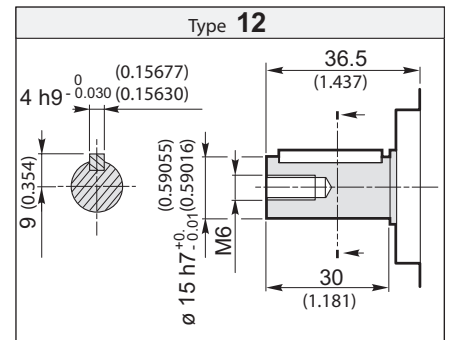

Torque 98 Nm / 72.3 ft-lbs

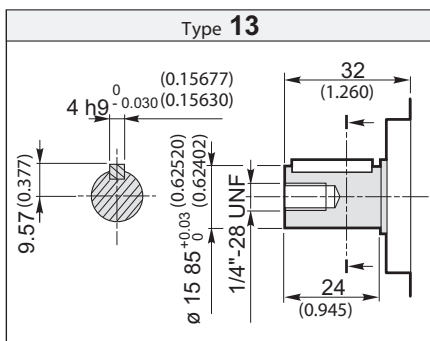

Torque 98 Nm / 72.3 ft-lbs

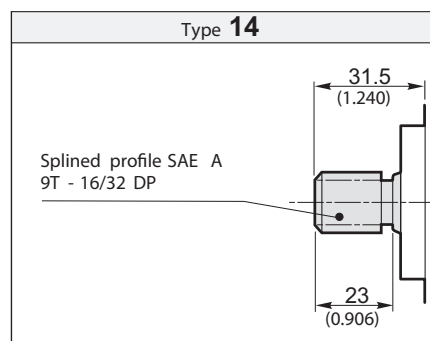

Torque 98 Nm / 72.3 ft-lbs

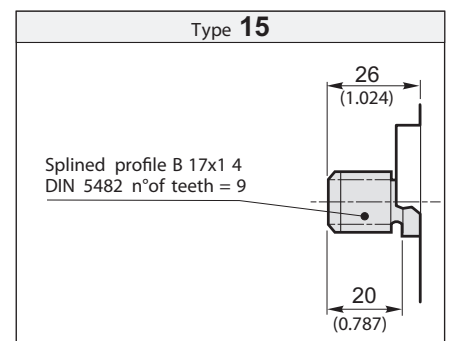

Torque 98 Nm / 72.3 ft-lbs

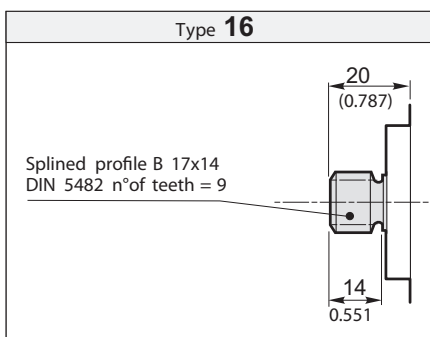

Torque 98 Nm / 72.3 ft-lbs

SEE PAGE 269 FOR PORT SIZES AVAILABLE

SEE PAGE 285 FOR PRICES

Technical data

Size	Displacement [cm ³ /rev] (in ³ /rev)	Max. working pressure			Max. speed [g/min] (rpm)	Max. flow [l/min] (Gal/min)	Min. speed [g/min] (rpm)	Min. flow [l/min] (Gal/min)	Dimensions		Mass [Kg] (lbs)	Min. volumetric efficiency %
		P1 [bar] (PSI)	P2 [bar] (PSI)	P3 [bar] (PSI)					A [mm] (inch)	B [mm] (inch)		
2SP A4	4 (0.24)	250 (3625)	270 (3915)	290 (4205)	4000	16 (4.23)	500	1.9 (0.50)	46.4 1.827	95 3.740	2.30 (5.07)	95*
2SP A6	6 (0.37)	250 (3625)	270 (3915)	290 (4205)	4000	24 (6.34)	500	2.85 (0.75)	48 1.890	98.3 3.870	2.45 (5.40)	
2SP A8	8.5 (0.52)	250 (3625)	270 (3915)	290 (4205)	3500	29.7 (7.85)	500	4.03 (1.06)	50.1 1.972	102.5 4.035	2.60 (5.73)	
2SP A11	11 (0.67)	250 (3625)	270 (3915)	290 (4205)	3500	38.5 (10.17)	500	5.22 (1.38)	52.2 2.055	106.6 4.197	2.70 (5.95)	
2SP A14	14 (0.85)	250 (3625)	270 (3915)	290 (4205)	3500	49 (12.95)	500	6.65 (1.76)	54.7 2.154	111.6 4.394	2.80 (6.17)	
2SP A16	16.5 (1.01)	230 (3335)	240 (3480)	250 (3625)	3500	57.7 (15.24)	500	7.83 (2.07)	56.8 2.236	115.8 4.559	2.95 (6.51)	
2SP A19	19.5 (1.19)	210 (3045)	220 (3190)	230 (3335)	3300	64.3 (16.99)	500	9.26 (2.45)	59.3 2.335	120.8 4.756	3.10 (6.84)	
2SP A22	22.5 (1.37)	190 (2755)	200 (2900)	210 (3045)	2800	63 (16.64)	500	10.68 (2.82)	61.8 2.433	125.8 4.953	3.25 (7.17)	
2SP A26	26 (1.59)	170 (2465)	180 (2610)	190 (2755)	2500	65 (17.17)	500	12.35 (3.26)	64.7 2.547	131.6 5.181	3.40 (7.50)	

* Value collected during the testing at 1500 rpm)

Example of ordering code

2SP | A | 14 | D | (H) | - | 10 | G | (VT)

2SP	Pump type	see table
A	Flange and cover	A = Aluminium
14	Displacement	see table
D	Clockwise rotation	D = Clockwise rotation S = Anticlockwise rotation
	Flange type	B80C
(H)	Stiffening seal for low suction pressure	(optional)
-		
10	Shaft type	10 - 11 - 12 - 13 - 14 - 15 - 16
G	Connections type	G - N - T - M - U - W - F
(VT)	Optional	(VT) Viton seals (optional) VLP-I (N) - VLP-E (N) Pressure relief valve (page A-49)

Conn Port Connections

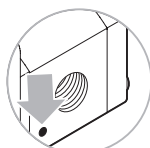
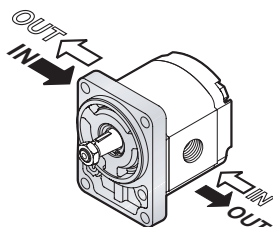
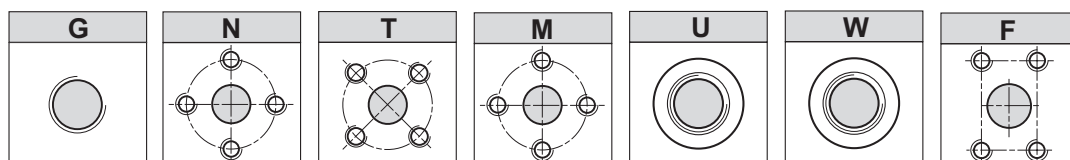

The sign on the body identifies the **suction side** for the pumps.

Rotation	
D	S

SEE PAGE 285 FOR PRICES

Dimensions

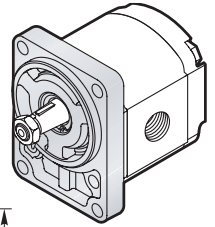
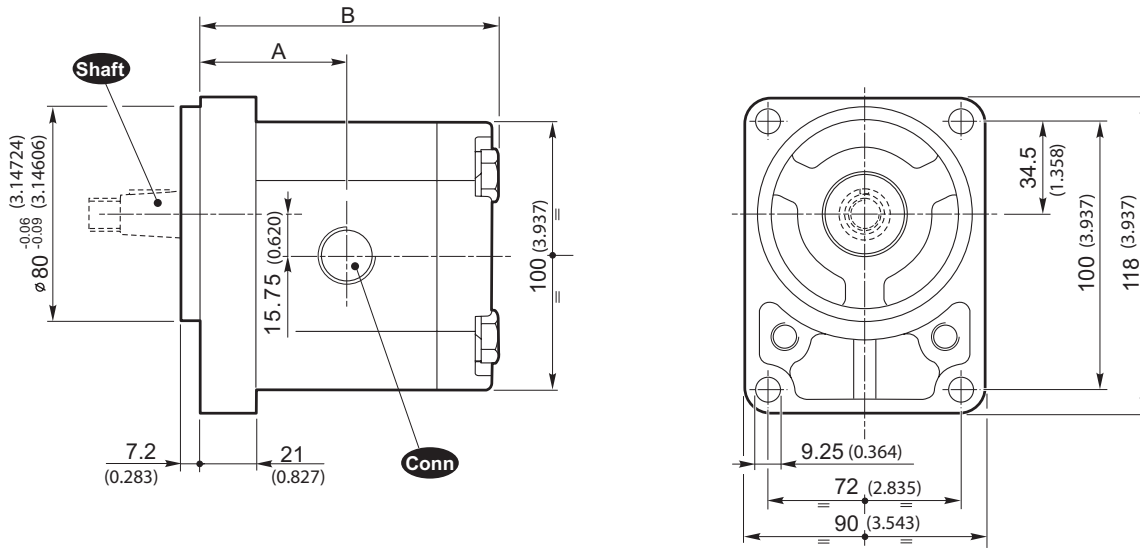

Shaft Available shafts

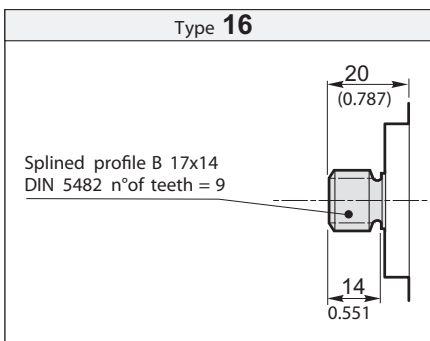
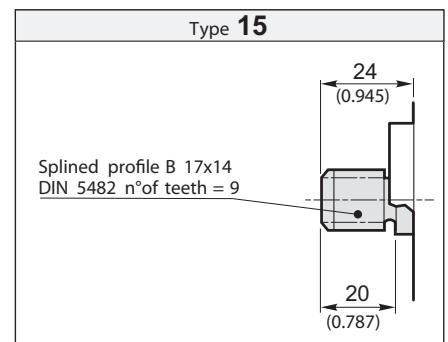
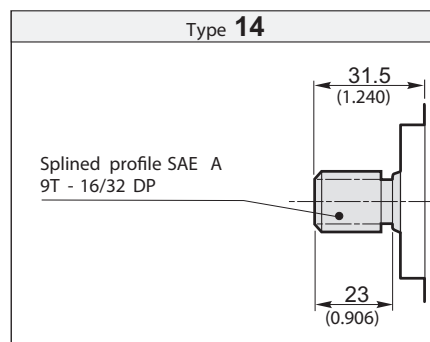
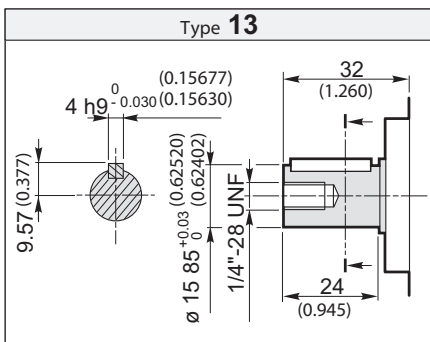
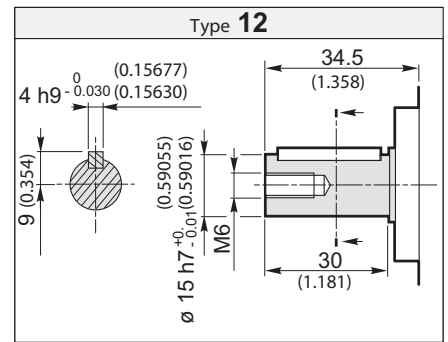
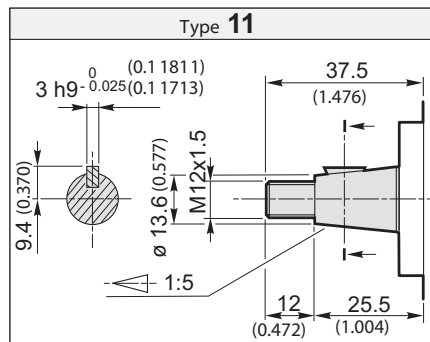
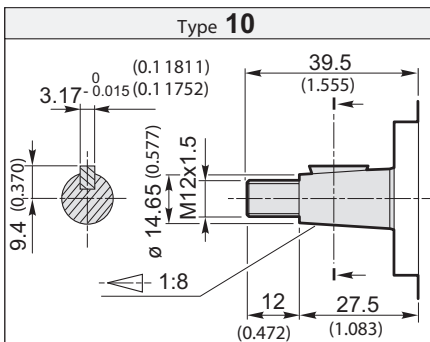

SEE PAGE 269 FOR PORT SIZES AVAILABLE

SEE PAGE 285 FOR PRICES

Technical data

Size	Displacement [cm ³ /rev] (in ³ /rev)	Max. working pressure			Max. speed [g/min] (rpm)	Max. flow [l/min] (Gal/min)	Min. speed [g/min] (rpm)	Min. flow [l/min] (Gal/min)	Dimensions				Mass [Kg] (lbs)	Min. volumetric efficiency %
		P1 [bar] (PSI)	P2 [bar] (PSI)	P3 [bar] (PSI)					A [mm] (inch)	B [mm] (inch)	C [mm] (inch)	L 1 [mm] (inch)		
2SP A4	4 (0.24)	250 (3625)	270 (3915)	290 (4205)	4000	16 (4.23)	500	1.9 (0.50)	44.4 (1.748)	93 (3.661)	84 (3.307)	105 (4.134)	2.30 (5.07)	95*
2SP A6	6 (0.37)	250 (3625)	270 (3915)	290 (4205)	4000	24 (6.34)	500	2.85 (0.75)	46 (1.811)	96.3 (3.791)	87.3 (3.437)	105 (4.134)	2.45 (5.40)	
2SP A8	8.5 (0.52)	250 (3625)	270 (3915)	290 (4205)	3500	29.7 (7.85)	500	4.03 (1.06)	48.1 (1.894)	100.5 (3.957)	91.5 (3.602)	110 (4.331)	2.60 (5.73)	
2SP A11	11 (0.67)	250 (3625)	270 (3915)	290 (4205)	3500	38.5 (10.17)	500	5.22 (1.38)	50.2 (1.976)	104.6 (4.118)	95.6 (3.764)	115 (4.528)	2.70 (5.95)	
2SP A14	14 (0.85)	250 (3625)	270 (3915)	290 (4205)	3500	49 (12.95)	500	6.65 (1.76)	52.7 (2.075)	109.6 (4.315)	100.6 (3.961)	120 (4.724)	2.80 (6.17)	
2SP A16	16.5 (1.01)	230 (3335)	240 (3480)	250 (3625)	3500	57.7 (15.24)	500	7.83 (2.07)	54.8 (2.157)	113.8 (4.480)	104.8 (4.126)	125 (4.921)	2.95 (6.51)	
2SP A19	19.5 (1.19)	210 (3045)	220 (3190)	230 (3335)	3300	64.3 (16.99)	500	9.26 (2.45)	57.3 (2.256)	118.8 (4.677)	109.8 (4.323)	130 (5.118)	3.10 (6.84)	
2SP A22	22.5 (1.37)	190 (2755)	200 (2900)	210 (3045)	2800	63 (16.64)	500	10.68 (2.82)	59.8 (2.354)	123.8 (4.874)	114.8 (4.520)	135 (5.315)	3.25 (7.17)	
2SP A26	26 (1.59)	170 (2465)	180 (2610)	190 (2755)	2500	65 (17.17)	500	12.35 (3.26)	62.7 (2.469)	129.6 (5.102)	120.6 (4.748)	140 (5.512)	3.40 (7.50)	

* Value collected during the testing at 1500 rpm

Example of ordering code

2SP | A | 14 | D | (H) | - | 10 | G | (VT)

2SP	Pump type	see table
A	Flange and cover	A = Aluminium
14	Displacement	see table
D	Clockwise rotation	D = Clockwise rotation S = Anticlockwise rotation
	Flange type	B50CX - B50CY
(H)	Stiffening seal for low suction pressure	(optional)
—		
10	Shaft type	10 - 11 - 12 - 13 - 14 - 15 - 16
G	Connections type	G - N - T - M - U - W - F
(VT)	Optional	(VT) Viton seals (optional) VLP-I (N) - VLP-E (N) Pressure relief valve (page A-49)

Conn Port Connections

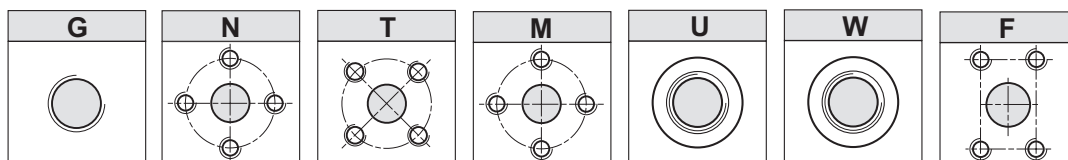

Version
B50CX

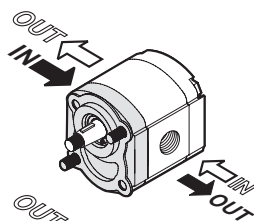

Version
B50CY

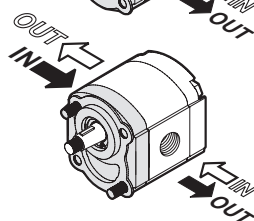

The sign on the body identifies the **suction side** for the pumps.

Rotation	
D	S

SEE PAGE 285 FOR PRICES

Dimensions

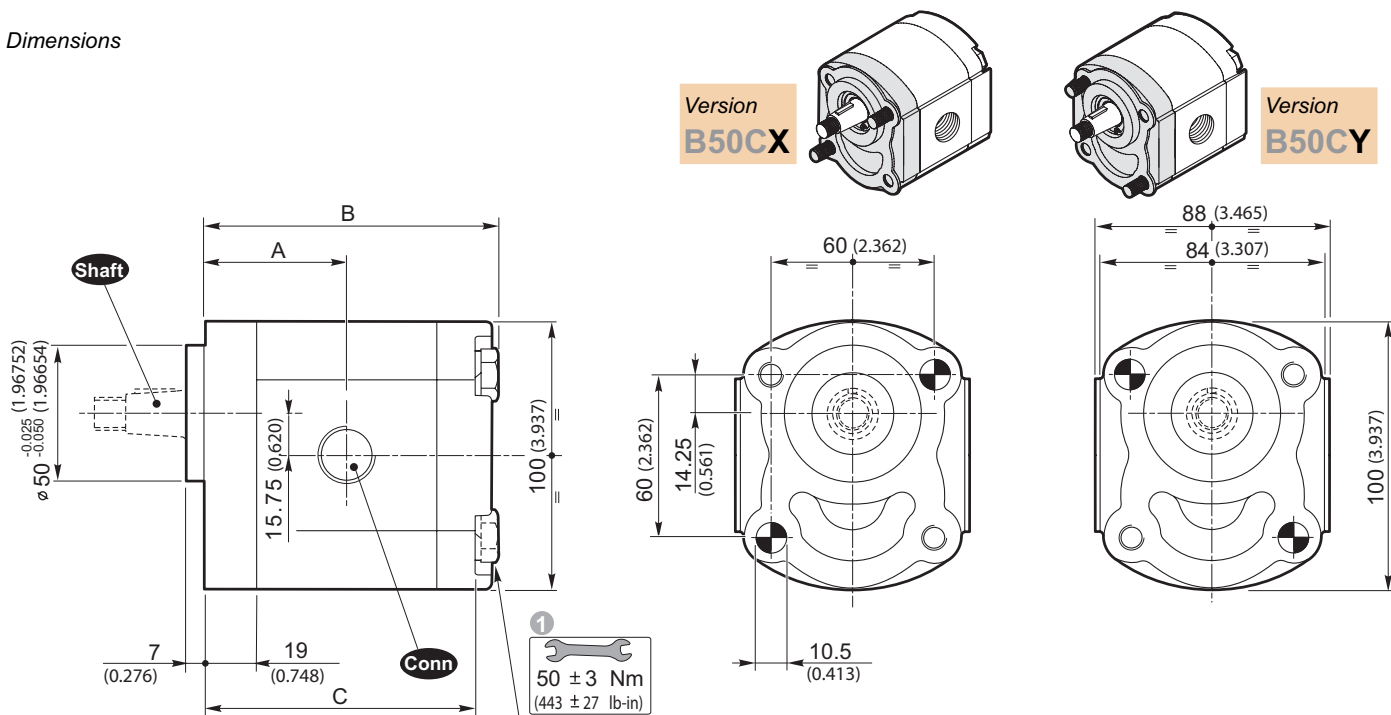

Shaft Available shafts

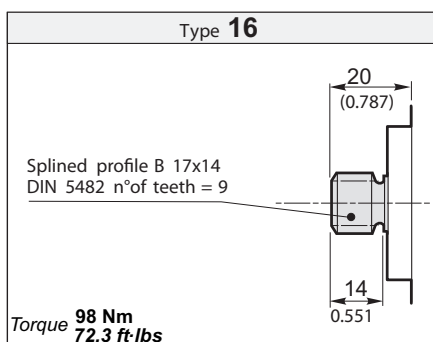
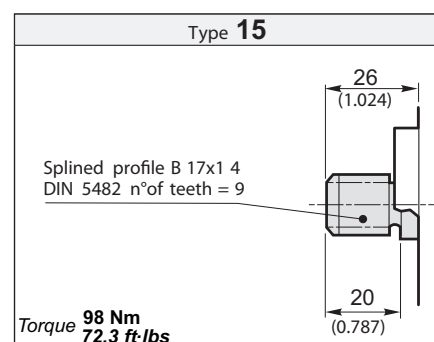
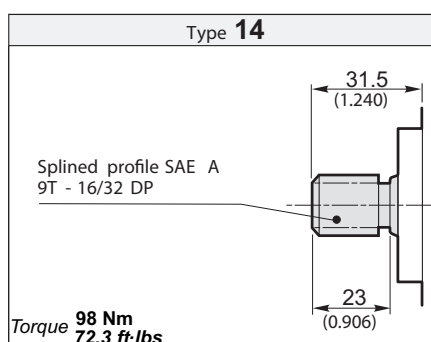
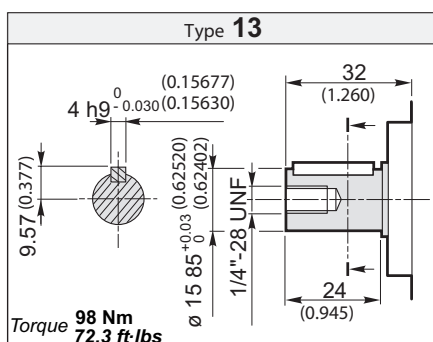
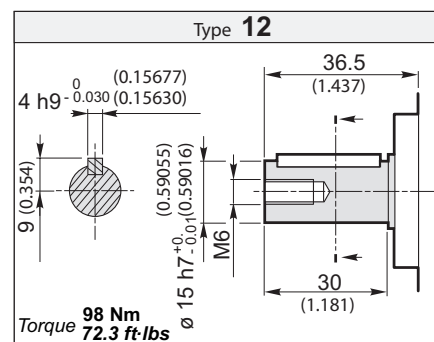
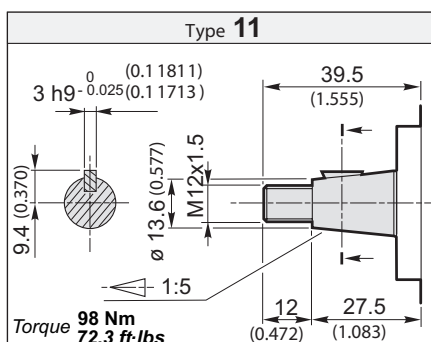
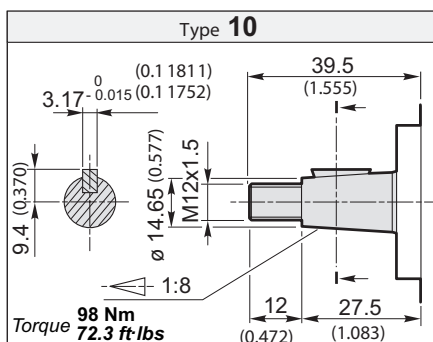

1 Tightening torque of screws: 443 ± 27 lb-in. Use screws type 10.9 - 12.9 UNI EN 20898/1.

The assembling of the pump should be effected with 2 screw studs type 10.9 - 12.9 pre-tighten at 354 ± 27 lb-in.
Fix the pump by self-locking nuts with tightening torque 443 ± 27 lb-in.

SEE PAGE 269 FOR PORT SIZES AVAILABLE

The screws kit for the pump assembling should be ordered separately. Ordering code of fixing Kit:

0029W + Lenght L (see table)

SEE PAGE 285 FOR PRICES

Technical data

Size	Displacement [cm ³ /rev] (in ³ /rev)	Max. working pressure			Max. speed [g/min] (rpm)	Max. flow [l/min] (Gal/min)	Min. speed [g/min] (rpm)	Min. flow [l/min] (Gal/min)	Dimensions				Mass [Kg] (lbs)	Min. volumetric efficiency %
		P1 [bar] (PSI)	P2 [bar] (PSI)	P3 [bar] (PSI)					A [mm] (inch)	B [mm] (inch)	C [mm] (inch)	L 1 [mm] (inch)		
2SP A4	4 (0.24)	250 (3625)	270 (3915)	290 (4205)	4000	16 (4.23)	500	1.9 (0.50)	41.7 (1.642)	90.3 (3.555)	81.3 (3.201)	100 (3.937)	2.30 (5.07)	95*
2SP A6	6 (0.37)	250 (3625)	270 (3915)	290 (4205)	4000	24 (6.34)	500	2.85 (0.75)	43.3 (1.705)	93.6 (3.685)	84.6 (3.331)	105 (4.134)	2.45 (5.40)	
2SP A8	8.5 (0.52)	250 (3625)	270 (3915)	290 (4205)	3500	29.7 (7.85)	500	4.03 (1.06)	45.4 (1.787)	97.8 (3.850)	88.8 (3.496)	110 (4.331)	2.60 (5.73)	
2SP A11	11 (0.67)	250 (3625)	270 (3915)	290 (4205)	3500	38.5 (10.17)	500	5.22 (1.38)	47.5 (1.870)	101.9 (4.012)	92.9 (3.657)	115 (4.528)	2.70 (5.95)	
2SP A14	14 (0.85)	250 (3625)	270 (3915)	290 (4205)	3500	49 (12.95)	500	6.65 (1.76)	50 (1.969)	106.9 (4.209)	97.9 (3.854)	120 (4.724)	2.80 (6.17)	
2SP A16	16.5 (1.01)	230 (3335)	240 (3480)	250 (3625)	3500	57.7 (15.24)	500	7.83 (2.07)	52.1 (2.051)	111.1 (4.374)	102.1 (4.020)	120 (4.724)	2.95 (6.51)	
2SP A19	19.5 (1.19)	210 (3045)	220 (3190)	230 (3335)	3300	64.3 (16.99)	500	9.26 (2.45)	54.6 (2.150)	116.1 (4.571)	107.1 (4.217)	125 (4.921)	3.10 (6.84)	
2SP A22	22.5 (1.37)	190 (2755)	200 (2900)	210 (3045)	2800	63 (16.64)	500	10.68 (2.82)	57.1 (2.248)	121.1 (4.768)	112.1 (4.413)	130 (5.118)	3.25 (7.17)	
2SP A26	26 (1.59)	170 (2465)	180 (2610)	190 (2755)	2500	65 (17.17)	500	12.35 (3.26)	60 (2.362)	126.9 (4.996)	117.9 (4.642)	140 (5.512)	3.40 (7.50)	

* Value collected during the testing at 1500 rpm)

Example of ordering code

2SP | A | 14 | D | E53CX | (H) | - | 10 | G | (VT)

2SP	Pump type	see table
A	Flange and cover	A = Aluminium
14	Displacement	see table
D	Clockwise rotation	D = Clockwise rotation S = Anticlockwise rotation
E52CX	Flange type	E52CX - E52CY
(H)	Stiffening seal for low suction pressure	(optional)
—		
10	Shaft type	17
G	Connections type	G - N - T - M - U - W - F
(VT)	Optional	(VT) Viton seals (optional) VLP-I (N) - VLP-E (N) Pressure relief valve (page A-49)

Conn Port Connections

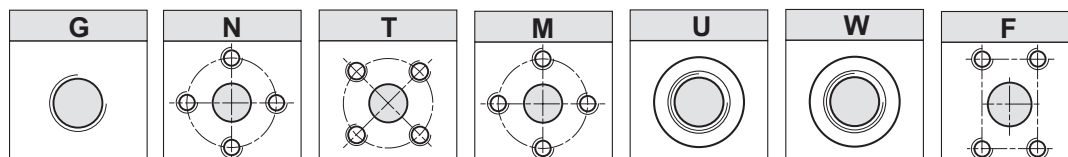

Version
E52CX

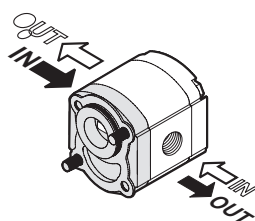

The sign on the body identifies the **suction side** for the pumps.

Version
E52CY

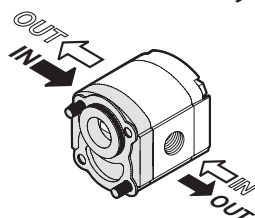

Rotation	
D	S

SEE PAGE 285 FOR PRICES

Dimensions

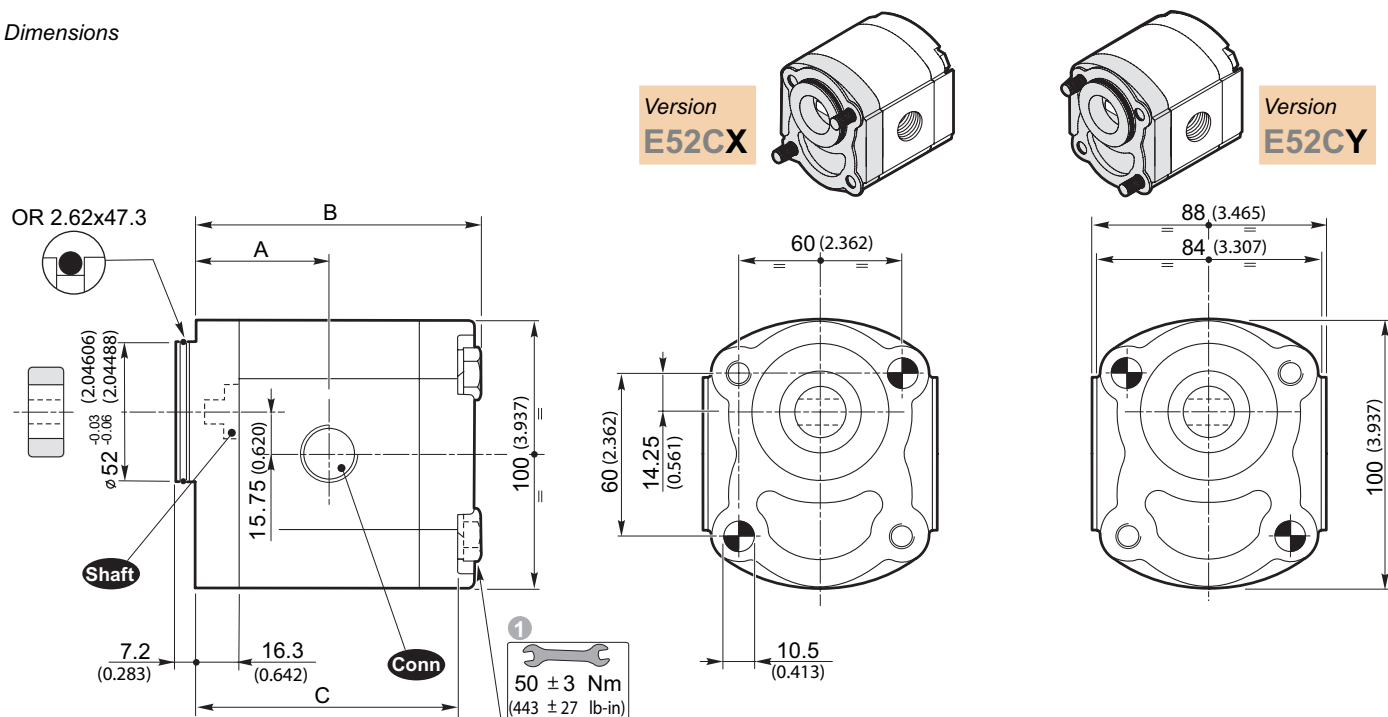

Shaft Available shafts

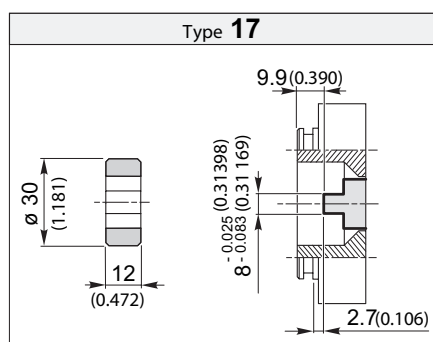

Torque 70 Nm / 51.6 ft-lbs

SEE PAGE 269 FOR PORT SIZES AVAILABLE

1
Tightening torque of screws: 443 ± 27 lb-in. Use screws type 10.9 - 12.9 UNI EN 20898/1.

The assembling of the pump should be effected with 2 screw studs type 10.9 - 12.9 pre-tighten at 354 ± 27 lb-in. Fix the pump by self-locking nuts with tightening torque 443 ± 27 lb-in.

The screws kit for the pump assembling should be ordered separately. Ordering code of fixing Kit:

0029W + Length L (see table)

SEE PAGE 285 FOR PRICES

PUMPS GROUP 2 • PRKS 400 D



Technical data

Size	Displacement [cm ³ /rev] (in ³ /rev)	Max. working pressure			Max. speed [g/min] (rpm)	Max. flow [lt/min] (Gal/min)	Min. speed [g/min] (rpm)	Min. flow [lt/min] (Gal/min)	Dimensions		Mass [Kg] (lbs)	Min. volumetric efficiency %
		P1 [bar] (PSI)	P2 [bar] (PSI)	P3 [bar] (PSI)					A [mm] (inch)	B [mm] (inch)		
2SP A4	4 (0.24)	250 (3625)	270 (3915)	290 (4205)	4000	16 (4.23)	500	1.9 (0.50)	44.4 (1.748)	93 (3.661)	2.30 (5.07)	95*
2SP A6	6 (0.37)	250 (3625)	270 (3915)	290 (4205)	4000	24 (6.34)	500	2.85 (0.75)	46 (1.811)	96.3 (3.791)	2.45 (5.40)	
2SP A8	8.5 (0.52)	250 (3625)	270 (3915)	290 (4205)	3500	29.7 (7.85)	500	4.03 (1.06)	48.1 (1.894)	100.5 (3.957)	2.60 (5.73)	
2SP A11	11 (0.67)	250 (3625)	270 (3915)	290 (4205)	3500	38.5 (10.17)	500	5.22 (1.38)	50.2 (1.976)	104.6 (4.118)	2.70 (5.95)	
2SP A14	14 (0.85)	250 (3625)	270 (3915)	290 (4205)	3500	49 (12.95)	500	6.65 (1.76)	52.7 (2.075)	109.6 (4.315)	2.80 (6.17)	
2SP A16	16.5 (1.01)	230 (3335)	240 (3480)	250 (3625)	3500	57.7 (15.24)	500	7.83 (2.07)	54.8 (2.157)	113.8 (4.480)	2.95 (6.51)	
2SP A19	19.5 (1.19)	210 (3045)	220 (3190)	230 (3335)	3300	64.3 (16.99)	500	9.26 (2.45)	57.3 (2.256)	118.8 (4.677)	3.10 (6.84)	
2SP A22	22.5 (1.37)	190 (2755)	200 (2900)	210 (3045)	2800	63 (16.64)	500	10.68 (2.82)	59.8 (2.354)	123.8 (4.874)	3.25 (7.17)	
2SP A26	26 (1.59)	170 (2465)	180 (2610)	190 (2755)	2500	65 (17.17)	500	12.35 (3.26)	62.7 (2.469)	129.6 (5.102)	3.40 (7.50)	

* Value collected during the testing at 1500 rpm)

Example of ordering code

2SP | A | 14 | D | PRKS 400 D | - | G

2SP	Pump type	see table
A	Flange and cover	A = Aluminium
14	Displacement	see table
D	Clockwise rotation	D = Clockwise rotation (usually supplied) S = Anticlockwise rotation
PRKS0400 D	Perkins flange	PRKS 400 D
-		
G	Connections type	G - N - T - M - U - W - F

Conn Port Connections

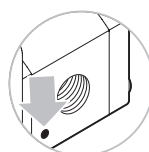
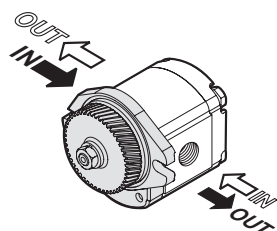
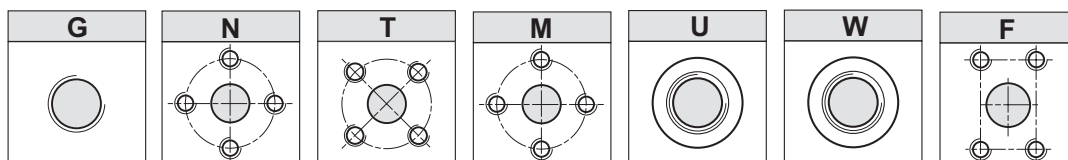

The sign on the body identifies the **suction side** for the pumps.

Rotation	
D	S

SEE PAGE 285 FOR PRICES

Dimensions

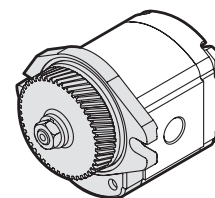
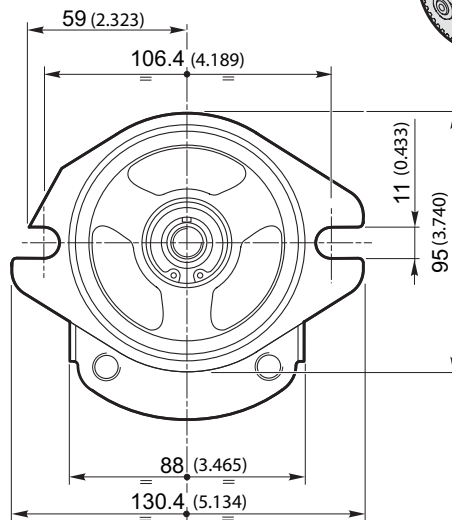
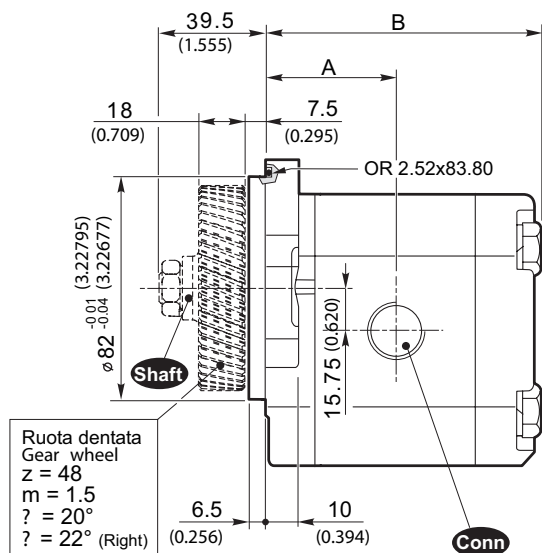

Ruota dentata
Gear wheel
z = 48
m = 1.5
? α = 20°
? α = 22° (Right)

Shaft Available shafts

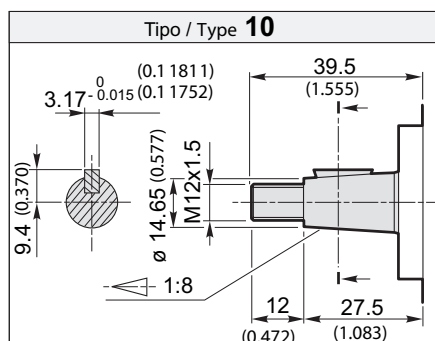

Torque 98 Nm / 72.3 ft-lbs

SEE PAGE 269 FOR PORT SIZES AVAILABLE

Technical data

SAE A 14* z = 10

Size	Displacement [cm ³ /rev] (in ³ /rev)	Max. working pressure			Max. speed [g/min] (rpm)	Max. flow [lt/min] (Gal/min)	Min. speed [g/min] (rpm)	Min. flow [lt/min] (Gal/min)	Dimensions		Mass [Kg] (lbs)	Min. volumetric efficiency %
		P1 [bar] (PSI)	P2 [bar] (PSI)	P3 [bar] (PSI)					A [mm] (inch)	B [mm] (inch)		
2SP ...8	8.5 (0.52)	250 (3625)	270 (3915)	290 (4205)	3500	29.7 (7.85)	500	4.03 (1.06)	48.1 (1.894)	100.5 (3.957)	2.65 (5.84)	95*
2SP ...11	11 (0.67)	250 (3625)	270 (3915)	290 (4205)	3500	38.5 (10.17)	500	5.22 (1.38)	50.2 (1.976)	104.6 (4.118)	2.75 (6.06)	
2SP ...26	26 (1.59)	170 (2465)	180 (2610)	190 (2755)	2500	65 (17.17)	500	12.35 (3.26)	62.7 (2.469)	129.6 (5.102)	3.45 (7.61)	

SAE A 14** z = 11

Size	Displacement [cm ³ /rev] (in ³ /rev)	Max. working pressure			Max. speed [rpm]	Max. flow [lt/min] (Gal/min)	Min. speed [rpm]	Min. flow [lt/min] (Gal/min)	Dimensions		Mass [Kg] (lbs)	Min. volumetric efficiency %
		P1 [bar] (PSI)	P2 [bar] (PSI)	P3 [bar] (PSI)					A [mm]	B [mm]		
2SP ...6	6 (0.37)	250 (3625)	270 (3915)	290 (4205)	4000	24 (6.34)	500	2.85 (0.75)	46 (1.811)	96.3 (3.791)	2.45 (5.40)	95*
2SP ...11	11 (0.67)	250 (3625)	270 (3915)	290 (4205)	3500	38.5 (10.17)	500	5.22 (1.38)	50.2 (1.976)	104.6 (4.118)	2.70 (5.95)	
2SP ...14	14 (0.85)	250 (3625)	270 (3915)	290 (4205)	3500	49 (12.95)	500	6.65 (1.76)	52.7 (2.075)	109.6 (4.315)	2.80 (6.17)	

* Value collected during the testing at 1500 rpm)

Example of ordering code

2SP | A | 26 | D | SAEA | - | 14* | G

2SP	Pump type	see table
A	Flange and cover	A = Aluminium G = Cast-iron flange and cover
26	Displacement	see table
D	Clockwise rotation	D = Clockwise rotation S = Anticlockwise rotation
SAEA	Flange type	SAE A
-		
14*	Shaft type	14* - 14**
G	Connections type	G - N - T - M - U - W - F

Conn Port Connections

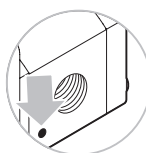
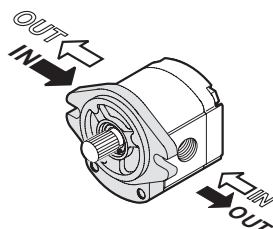
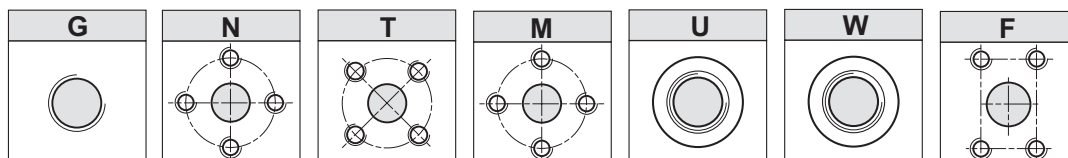

The sign on the body identifies the **suction side** for the pumps.

Rotation	
D	S

SEE PAGE 285 FOR PRICES

Dimensions

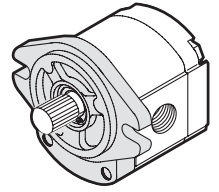
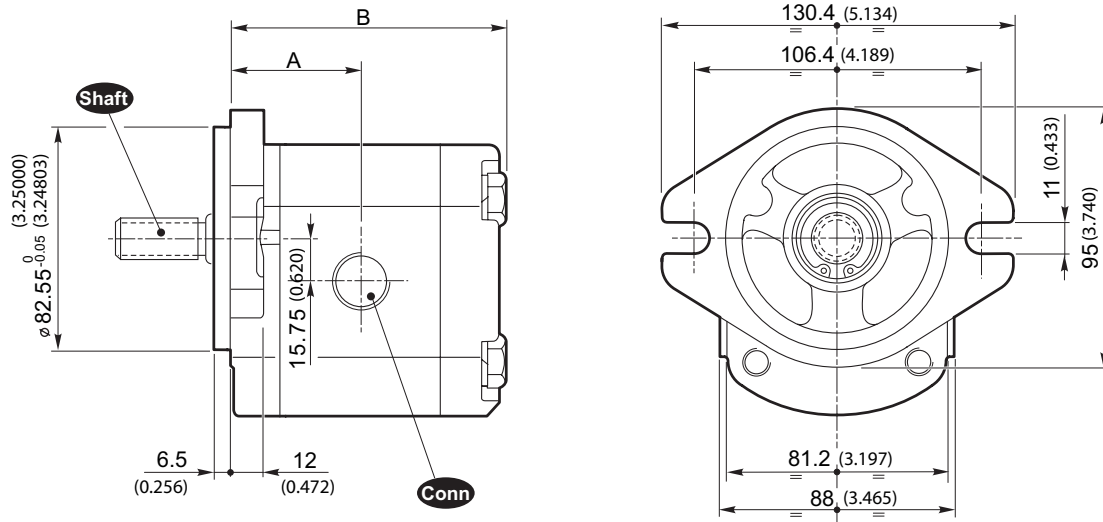

Shaft Available shafts

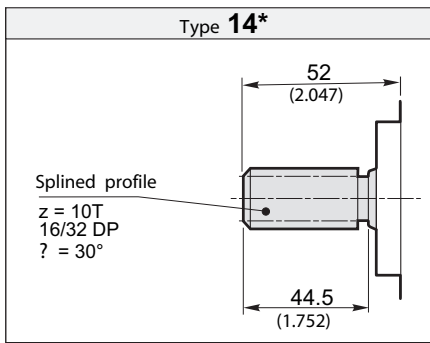

Torque 98 Nm / 72.3 ft-lbs

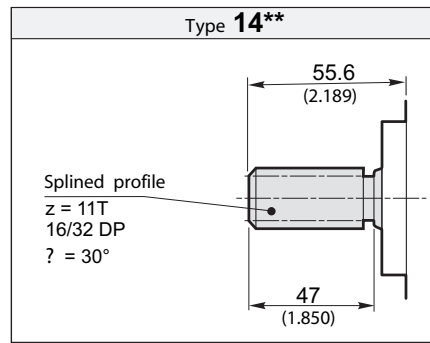

Torque 98 Nm / 72.3 ft-lbs

SEE PAGE 269 FOR PORT SIZES AVAILABLE

Version to use with axial and/or radial loads

Technical data

Size	Displacement [cm ³ /rev] (in ³ /rev)	Max. working pressure			Max. speed [g/min] (rpm)	Max. flow [l/min] (Gal/min)	Min. speed [g/min] (rpm)	Min. flow [l/min] (Gal/min)	Dimensions		Mass [Kg] (lbs)	Min. volumetric efficiency %
		P1 [bar] (PSI)	P2 [bar] (PSI)	P3 [bar] (PSI)					A [mm] (inch)	B [mm] (inch)		
2SP A4	4 (0.24)	250 (3625)	270 (3915)	290 (4205)	4000	16 (4.23)	500	1.9 (0.50)	64.4 (2.535)	113 (4.449)	2.8 (6.17)	95*
2SP A6	6 (0.37)	250 (3625)	270 (3915)	290 (4205)	4000	24 (6.34)	500	2.85 (0.75)	66 (2.598)	116.3 (4.579)	2.95 (6.50)	
2SP A8	8.5 (0.52)	250 (3625)	270 (3915)	290 (4205)	3500	29.7 (7.85)	500	4.03 (1.06)	68.1 (2.681)	120.5 (4.744)	3.1 (6.84)	
2SP A11	11 (0.67)	250 (3625)	270 (3915)	290 (4205)	3500	38.5 (10.17)	500	5.22 (1.38)	70.2 (2.764)	124.6 (4.906)	3.2 (7.06)	
2SP A14	14 (0.85)	250 (3625)	270 (3915)	290 (4205)	3500	49 (12.95)	500	6.65 (1.76)	72.7 (2.862)	129.6 (5.102)	3.3 (7.28)	
2SP A16	16.5 (1.01)	230 (3335)	240 (3480)	250 (3625)	3500	57.7 (15.24)	500	7.83 (2.07)	74.8 (2.945)	133.8 (5.268)	3.45 (7.61)	
2SP A19	19.5 (1.19)	210 (3045)	220 (3190)	230 (3335)	3300	64.3 (16.99)	500	9.26 (2.45)	77.3 (3.043)	138.8 (5.465)	3.6 (7.94)	
2SP A22	22.5 (1.37)	190 (2755)	200 (2900)	210 (3045)	2800	63 (16.64)	500	10.68 (2.82)	79.8 (3.142)	143.8 (5.661)	3.75 (8.27)	
2SP A26	26 (1.59)	170 (2465)	180 (2610)	190 (2755)	2500	65 (17.17)	500	12.35 (3.26)	82.7 (3.256)	149.6 (5.890)	3.9 (8.60)	

* Value collected during the testing at 1500 rpm

Example of ordering code

2SP | A | 14 | D | SUPP.STND | - | 10 | G | (VT)

2SP	Pump type	see table
A	Flange and cover	A = Aluminium
14	Displacement	see table
D	Clockwise rotation	D = Clockwise rotation S = Anticlockwise rotation
SUPP.STND	Support type	SUPP.STND
-		
10	Shaft type	10
G	Connections type	G - N - T - M - U - W - F
(VT)	Optional	(VT) Viton seals (optional) VLP-I (N) - VLP-E (N) Pressure relief valve (page A-49)

It is not necessary to indicate STANDARD flange

Conn Port Connections

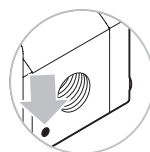
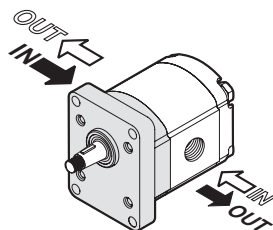
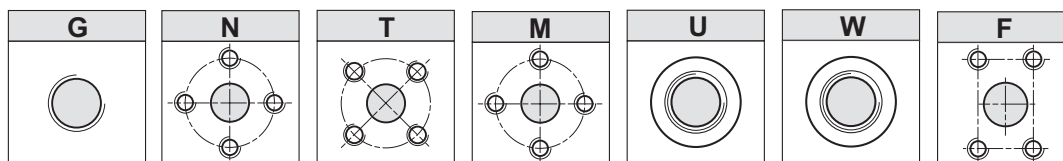

The sign on the body identifies the **suction side** for the pumps.

Rotation	
D	S

SEE PAGE 285 FOR PRICES

Version to be chosen with axial and/or radial loads

Dimensions

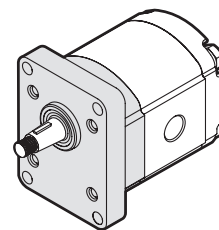
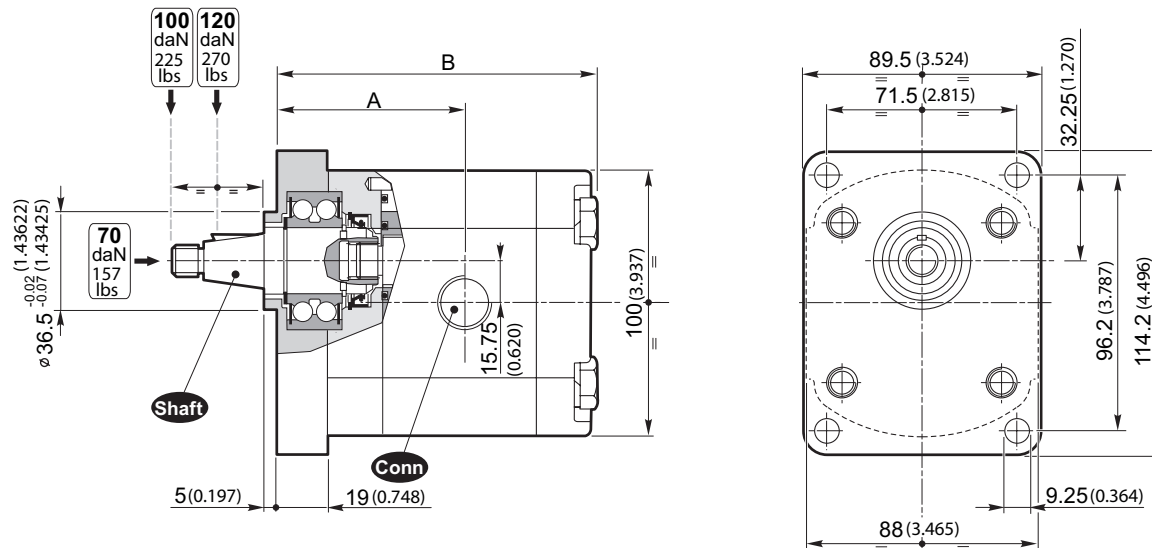

Shaft Available shafts

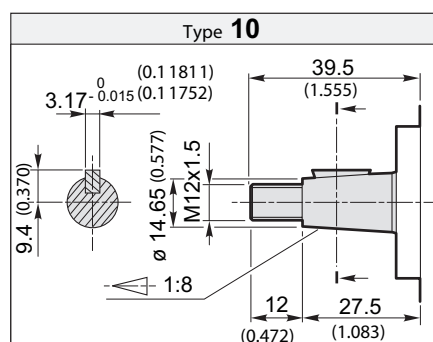

SEE PAGE 269 FOR PORT SIZES AVAILABLE

SEE PAGE 285 FOR PRICES

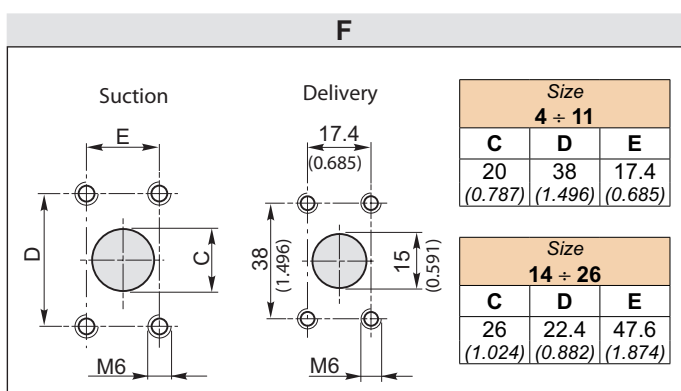
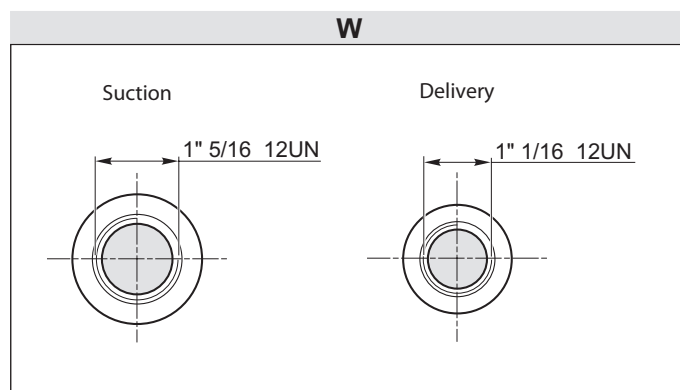
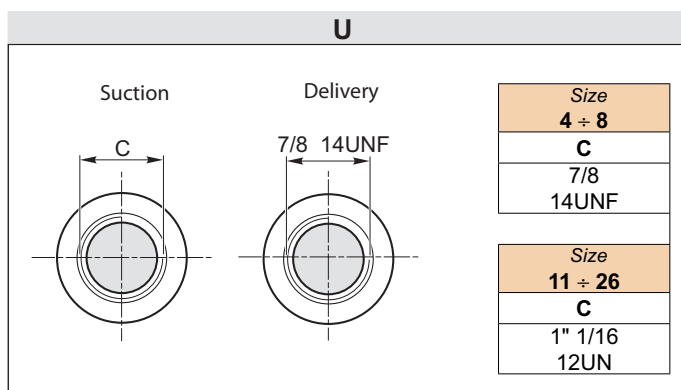
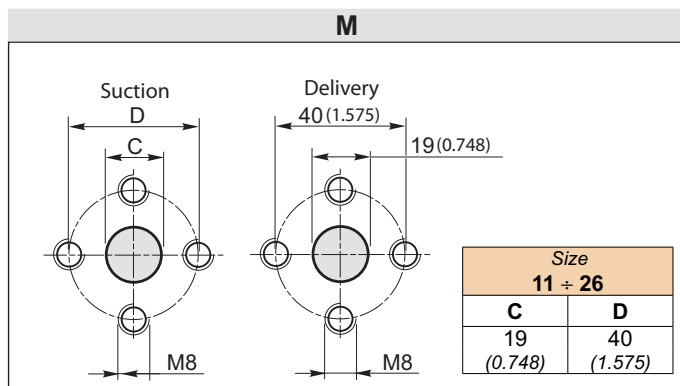
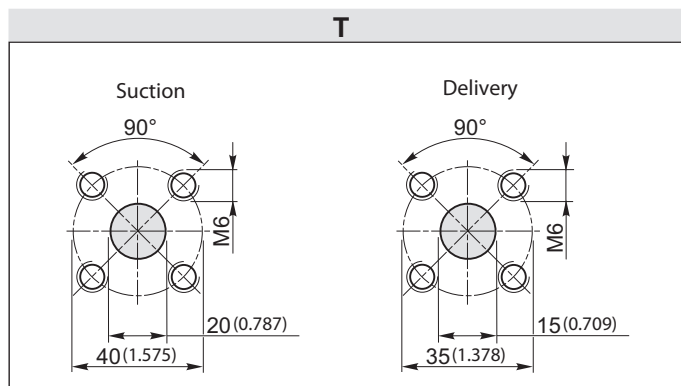
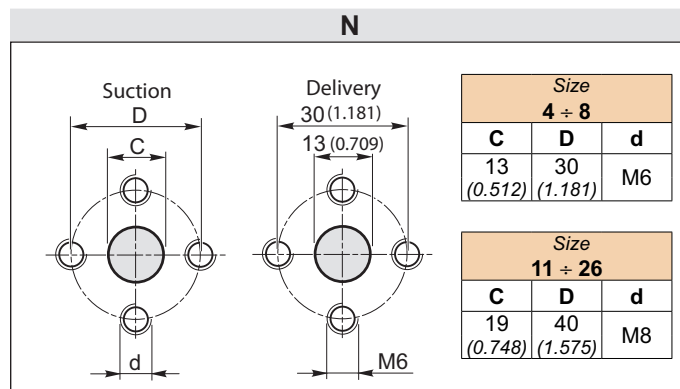
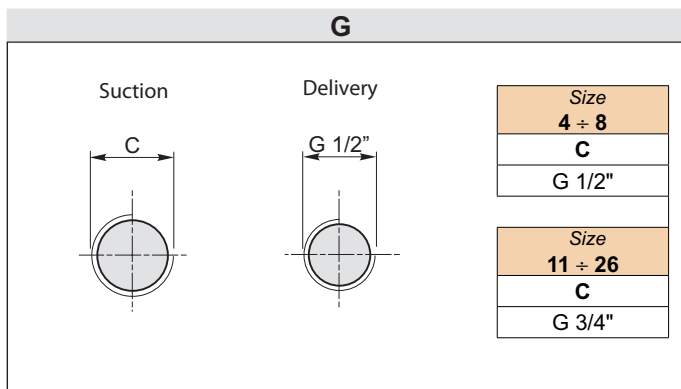

The sign on the body identifies the **suction side** for the pumps.

Port Connections position

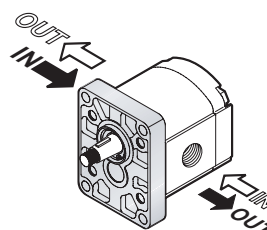

Rotation	
D	S

SEE PAGE 285 FOR PRICES

VLP- I (N)

Pressure relief valve with internal exhaust

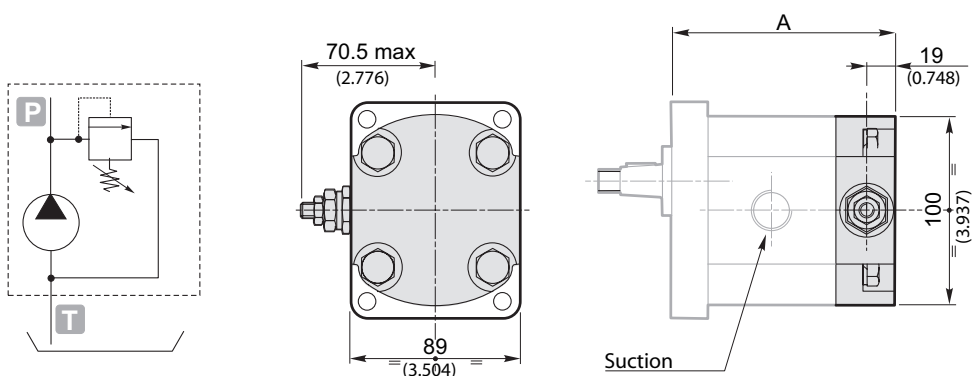

	A		
	Standard SAE A B50C	B80C	E52C
2SP A4	104.8 (4.126)	106.8 (4.205)	102.1 (4.020)
2SP A6	108.1 (4.256)	110.1 (4.335)	105.4 (4.150)
2SP A8	112.3 (4.421)	114.3 (4.500)	109.6 (4.315)
2SP A11	116.4 (4.583)	118.4 (4.661)	113.7 (4.476)
2SP A14	121.4 (4.780)	123.4 (4.858)	118.7 (4.673)
2SP A16	125.6 (4.945)	127.6 (5.024)	122.9 (4.839)
2SP A19	130.6 (5.142)	132.6 (5.220)	127.9 (5.035)
2SP A22	135.6 (5.339)	137.6 (5.417)	132.9 (5.232)
2SP A26	141.4 (5.567)	143.4 (5.646)	138.7 (5.461)

VLP- E (N)

Pressure relief valve with external exhaust

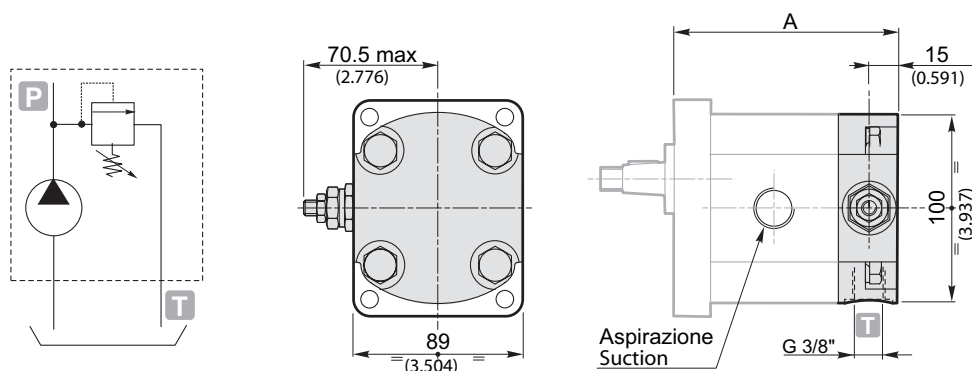

	A		
	Standard SAE A B50C	B80C	E52C
2SP A4	100.8 (3.969)	102.8 (4.047)	98.1 (3.862)
2SP A6	104.1 (4.098)	106.1 (4.177)	101.4 (3.992)
2SP A8	108.3 (4.264)	110.3 (4.343)	105.6 (4.157)
2SP A11	112.4 (4.425)	114.4 (4.504)	109.7 (4.319)
2SP A14	117.4 (4.622)	119.4 (4.701)	114.7 (4.516)
2SP A16	121.6 (4.787)	123.6 (4.866)	118.9 (4.681)
2SP A19	126.6 (4.984)	128.6 (5.063)	123.9 (4.878)
2SP A22	131.6 (5.181)	133.6 (5.260)	128.9 (5.075)
2SP A26	137.4 (5.409)	139.4 (5.488)	134.7 (5.303)

Warning.

The pressure relief valve can be applied by substituting the rear cover.

It is supplied only with aluminium flange and cover.

The showed pumps are anticlockwise rotation.

The opening of the pressure relief valve should be carry out for times not over 10" each minute to avoid the overheating of the pump.

SEE PAGE 269 FOR PORT SIZES AVAILABLE

Example of ordering code

2SP	A	14	D	SAE A	-	10	G	(VT)	VLP-I	(N)
VLP-I	Cover with VLP								VPL-I (at internal exhaust) VLP-E (at external exhaust)	
(N)	Spring type								B - N - R (See table)	
					Spring type					
					B		N		R	
					white spring		black spring		red spring	
Calibration fields*	[bar] (psi)	10 ÷ 100 (145 ÷ 1450)		30 ÷ 280 (435 ÷ 4060)		80 ÷ 380 (1160 ÷ 5510)				

* Without setting request, it will be considered standard (black spring: 2175 psi).

SEE PAGE 285 FOR PRICES

VRF

Priority flow divider valve

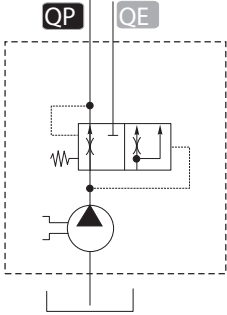
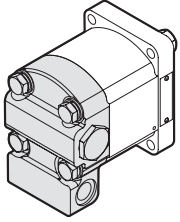

Exceeding flow to actuator or to tank

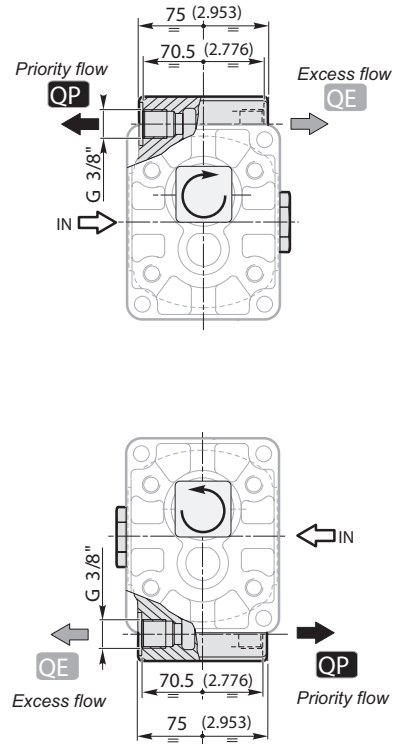
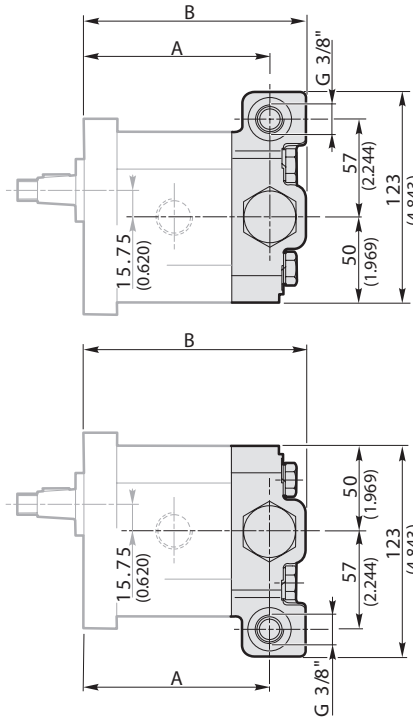

		2SP ... 4	2SP ... 6	2SP ... 8	2SP ... 11	2SP ... 14	2SP ... 16	2SP ... 19	2SP ... 22	2SP ... 26
A	Standard	91.8 (3.614)	95.1 (3.744)	99.3 (3.909)	103.4 (4.071)	108.4 (4.268)	112.6 (4.433)	117.6 (4.630)	122.6 (4.827)	128.4 (5.055)
	SAE AA	93.8 (3.693)	97.1 (3.823)	101.3 (3.988)	105.4 (4.150)	110.4 (4.346)	114.6 (4.512)	119.6 (4.709)	124.6 (4.906)	130.4 (5.134)
	E32 BX	89.1 (3.508)	92.4 (3.638)	92.4 (3.638)	100.7 (3.965)	105.7 (4.161)	109.9 (4.327)	114.9 (4.524)	119.9 (4.720)	125.7 (4.949)
	E32 CX									
B	Standard	112.8 (4.441)	116.1 (4.571)	120.3 (4.736)	124.4 (4.898)	129.4 (5.094)	133.6 (5.260)	138.6 (5.457)	143.6 (5.654)	149.4 (5.882)
	SAE AA	114.8 (4.520)	118.1 (4.650)	122.3 (4.815)	126.4 (4.976)	131.4 (5.173)	135.6 (5.339)	140.6 (5.535)	145.6 (5.732)	151.4 (5.961)
	E32 BX	110.1 (4.335)	113.4 (4.465)	117.6 (4.630)	121.7 (4.791)	126.7 (4.988)	130.9 (5.154)	135.9 (5.350)	140.9 (5.547)	146.7 (5.776)
	E32 CX									

Example of ordering code

2SP	A	14	D	SAEA	-	10	G	(VT)	VRF	(d)	
VRF	Cover with V R F						VRF				
(d)	Diameter of calibrated orifice						2.5 - 3 - 3.25 - 4 - 4.25 - 5.5 (See table)				

SEE PAGE 269 FOR PORT SIZES AVAILABLE

d [mm]	Q [l/min] (US.gal/min)
2.5	5 (1.32)
3	7 (1.32)
3.25	8 (1.32)
4	11 (1.32)
4.25	14 (1.32)
5.5	21 (1.32)

SEE PAGE 285 FOR PRICES

VRF - VLP-I

Priority flow divider valve and pressure relief valve

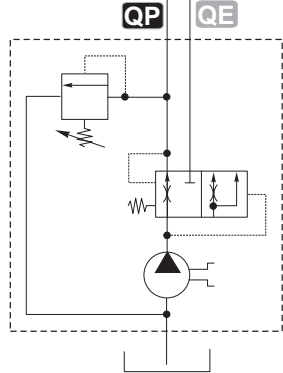
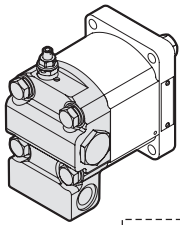

Exceeding flow to actuator or to tank

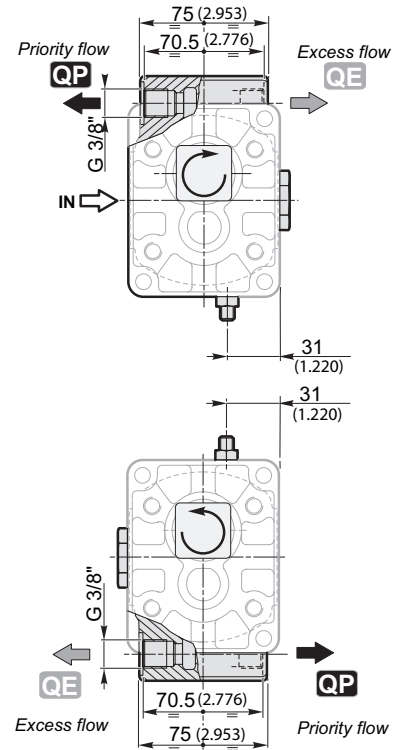
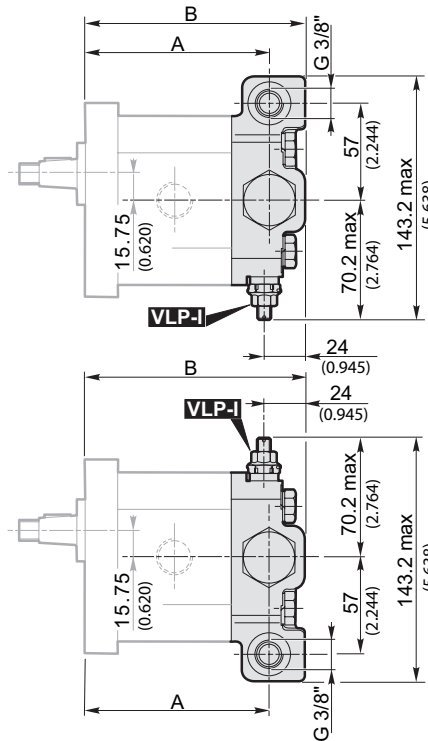

		2SP...4	2SP...6	2SP...8	2SP...11	2SP...14	2SP...16	2SP...19	2SP...22	2SP...26
A	Standard	91.8 (3.614)	95.1 (3.744)	99.3 (3.909)	103.4 (4.071)	108.4 (4.268)	112.6 (4.433)	117.6 (4.630)	122.6 (4.827)	128.4 (5.055)
	SAE AA	93.8 (3.693)	97.1 (3.823)	101.3 (3.988)	105.4 (4.150)	110.4 (4.346)	114.6 (4.512)	119.6 (4.709)	124.6 (4.906)	130.4 (5.134)
	E32 BX	89.1	92.4	92.4	100.7	105.7	109.9	114.9	119.9	125.7
	E32 CX	(3.508)	(3.638)	(3.638)	(3.965)	(4.161)	(4.327)	(4.524)	(4.720)	(4.949)
B	Standard	112.8 (4.441)	116.1 (4.571)	120.3 (4.736)	124.4 (4.898)	129.4 (5.094)	133.6 (5.260)	138.6 (5.457)	143.6 (5.654)	149.4 (5.882)
	SAE AA	114.8 (4.520)	118.1 (4.650)	122.3 (4.815)	126.4 (4.976)	131.4 (5.173)	135.6 (5.339)	140.6 (5.535)	145.6 (5.732)	151.4 (5.961)
	E32 BX	110.1	113.4	117.6	121.7	126.7	130.9	135.9	140.9	146.7
	E32 CX	(4.335)	(4.465)	(4.630)	(4.791)	(4.988)	(5.154)	(5.350)	(5.547)	(5.776)

Example of ordering code

2SP	A	14	D	SAE A	-	10	G	(VT)	VRF	(d)	-	VLP-I	(N)	
VRF	Cover with VRF								VRF					
(d)	Diameter of calibrated orifice								2.5 - 3 - 3.25 - 4 - 4.25 - 5.5 (See table)					
VLP-I	Cover with VLP								VLP-I (at internal exhaust)					
(N)	Spring type								B - N - R (See table)					

		Spring type		
		B	N	R
		white spring	black spring	red spring
Calibration fields*	[bar] (psi)	10 ÷ 100 (145 ÷ 1450)	30 ÷ 280 (435 ÷ 4060)	80 ÷ 380 (1160 ÷ 5510)
The complete range can be obtained with additional thickness				

d	Q
[mm]	[l/min] (US.gal/min)
2.5	5 (1.32)
3	7 (1.32)
3.25	8 (1.32)
4	11 (1.32)
4.25	14 (1.32)
5.5	21 (1.32)

* Without setting request, it will be considered standard (black spring: 2175 psi).

SEE PAGE 269 FOR PORT SIZES AVAILABLE

SEE PAGE 285 FOR PRICES